

Photovoltaic Engineering Module Experiments

Experiment 1:

The Current Voltage Relation or the IV Curve of a Solar Module

Syllabus Covered:

Engineering Electricity Electronic: Student learn to interpret IV curve

Aim:

- To observe the relationship of current, voltage and power in a solar cell
- To plot the I-V curve of a solar cell in excel, and to identify the maximum power point, the short circuit current, and the open circuit voltage

Abstract:

At short circuit, the solar module produces electric current but no voltage. At open circuit, the solar module produces voltage but no current. Electric power is defined as the product of the current and the voltage. Hence, in both the short circuit or open circuit, the solar module produces no power. Somewhere in between these two operating points is the Maximum Power point of the solar module where the maximum power possible is being generated. In this experiment the student is to find the values of voltage and respective current generated by the modules, find the power, and plot graphs.

Notes:

By taking current and voltage measurements of a solar module while supplying power to a variable resistor, the student determines the current-voltage relation, or what is called as IV curve of a solar module. This relation is graphed using a spreadsheet such as Microsoft Excel. The current and voltage of each data set is multiplied together to yield the corresponding power at that operating point. The power is then plotted as a function of voltage.

The maximum value of the power curve is at the maximum power point of the solar module. The student should determine the current, the voltage, and the power for the maximum power of the solar module

Equipments:

- One solar module
- One ammeter
- One voltmeter
- Variable Resistor
- Alligator clips and wire
- Artificial Light Source

Diagram:

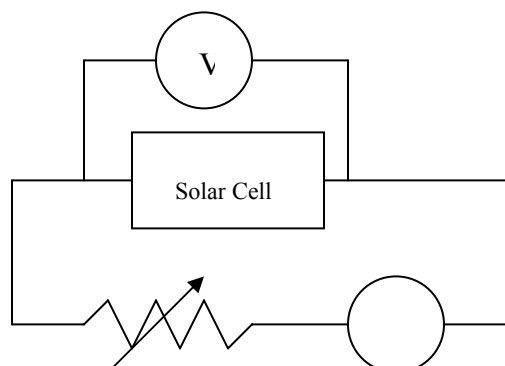

Method:

A

1. Set the circuit as in the diagram above (Ammeter is in series, Voltmeter parallel)
2. Set the solar cell facing towards a source of artificial light, such as an overhead projector light.
3. Measure the Short Circuit Current (by having maximum resistance) and Open Circuit Voltage (by disconnecting the variable resistor)
4. Change the resistance of the variable resistor, until a change in 10 milli-ampere occurs. Record the new current and voltage
5. When the rate of changes of voltage has increased, students should decrease the change in current (about 1 mA) to obtain more data points. Record the current and voltage measurement
6. Continue this until the maximum resistance in the variable resistor (when voltage = 0)
7. Place the data in MS. Excel. Plot the IV curve, with current in the vertical axis, and voltage in the horizontal axis.
8. The current and voltage of each data set is then multiplied together giving a value for power and placed in the adjacent column
9. Plot another graph, with power in the vertical axis, and the voltage in the horizontal axis. This is the power graph
10. Indicate the maximum power in the power curve, and find the respective voltage and current.

Result set up

Voltage (Volt)	Current (Amp)	Power(W)
2.2	0	0
1.89	0.35	0.6615
1.87	0.36	0.6732
1.86	0.37	0.6882
1.84	0.38	0.6992
1.82	0.39	0.7098
1.8	0.4	0.72
1.78	0.41	0.7298
1.76	0.42	0.7392
1.73	0.43	0.7439
1.7	0.44	0.748
1.67	0.45	0.7515
1.63	0.46	0.7498
1.57	0.47	0.7379
1.53	0.48	2.1744
1.46	0.49	0.7154
1.38	0.5	0.69
1.2	0.51	0.612
0.58	0.52	0.3016
0.22	0.53	0.1166
0	0.53	0

← Open Circuit Voltage

← Short Circuit Current

Note: The result above is just an example, student can obtain different result. But, the result should always have open circuit voltage (when current = 0), and the short circuit current (when voltage = 0)

Graph

Maximum Power Point

Note: This is what the graph should look like

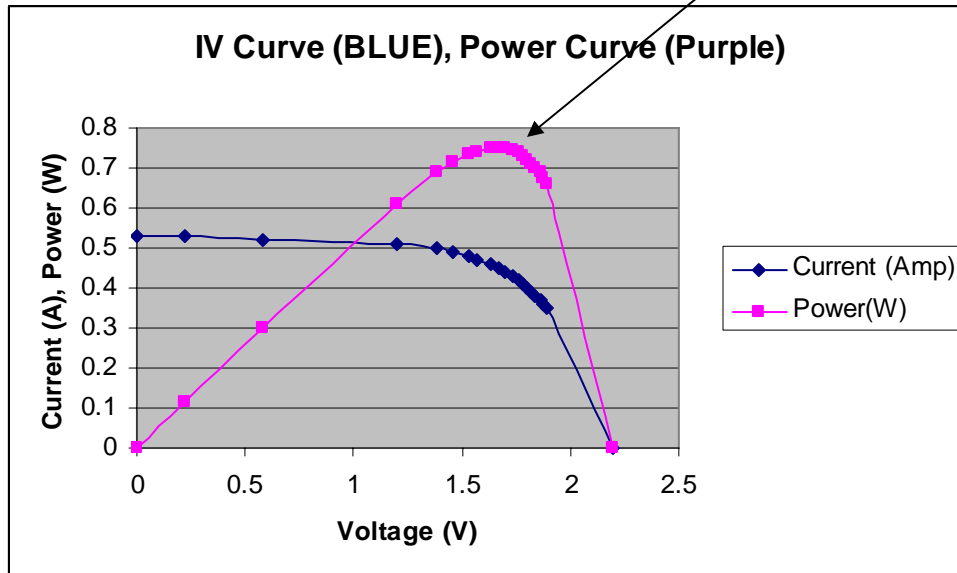

Results from graph

Maximum Power =

Voltage at maximum power point =

Current at maximum power point =

Discussion

Reliability:

- Whether the reading is repeated or not to make the result reliable

Validity:

- Are all the reading taken by the same equipments, same amount of sunshine, same condition?

Validity can be improved by repeating the same experiment, however with solar cell facing away from the source of light:

Extension

Aim

To compare the performance of solar cell in different illumination condition

Method (Extension)

1. Set the circuit as in the diagram above
2. Set the solar cell facing away from a source of artificial light.
3. Repeat method 3-10 above

Improvement:

- How can they be improved?

Experiment 2

Parallel and Series connection of resistors in a circuit to model the connection of photovoltaic module

Aim:

- To learn parallel and series connection of resistors in a circuit
- To observe the impact of different connection to the voltage and current through them the resistor

Abstract:

In connection solar cells into a usable module, manufacturer needs to connect the solar cells using different connections, i.e. parallel and series connection. It is important that students know their difference, and what happen to the voltage and current in these different connections, because in manufacturing, we need to know the amount of usable voltage and current and output from the modules.

Notes:

In a normal series connected circuit,

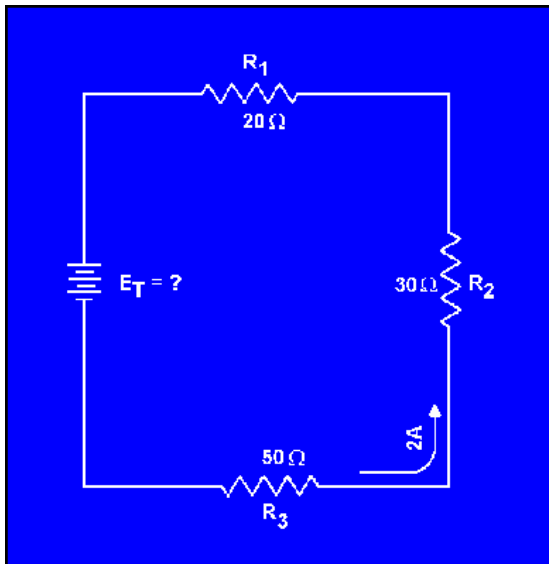

In the diagram above, the total voltage will be $V_T = V_{R1} + V_{R2} + V_{R3}$, i.e. the total voltage of the circuit is the addition of the voltage between each of the resistors.

Meanwhile, $I_{R1} = I_{R2} = I_{R3}$ (Current through all the resistors should be the same)

In a solar cell,

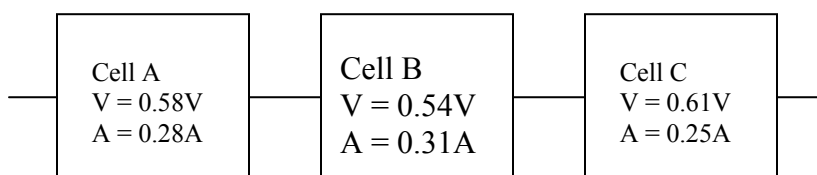

$$\begin{aligned}
 V_T &= V_A + V_B + V_C \\
 &= 0.58 + 0.54 + 0.61 \\
 &= 1.73 \text{ V}
 \end{aligned}$$

Meanwhile, just like resistors in series, the current passes through these solar cells should be equal as well. Therefore, the solar cell with the smallest current will be limiting the current of the rest of the solar cell. i.e. $I_T = I_C = 0.25 \text{ A}$

In a normal parallel circuit,

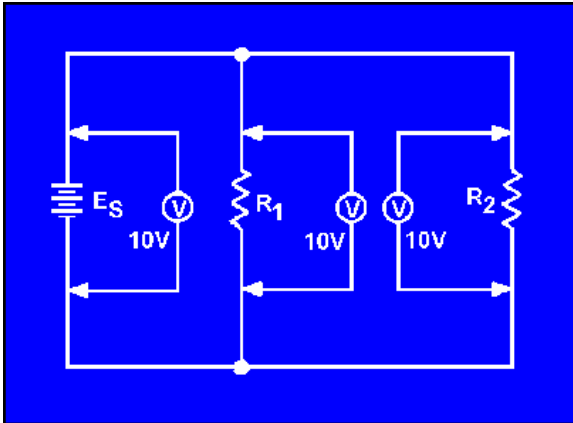

In parallel case, the voltage of the resistor is equal, i.e. $V_{ES} = V_{R1} = V_{R2} = 10\text{V}$

Meanwhile, the total current should be equal to the total of the current passes through R_1 and R_2 .

] For solar cells,

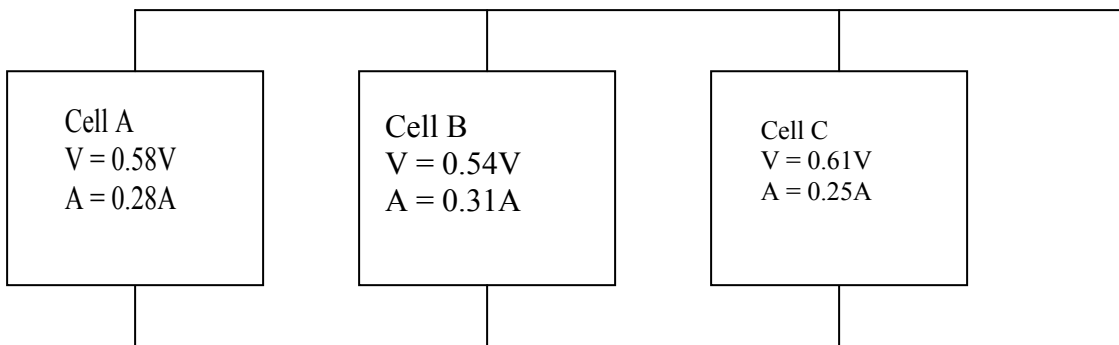

In this case, the voltage is limited by the smallest voltage, i.e. $V_T = V_B = 0.58 \text{ V}$

$$\begin{aligned}
 \text{Meanwhile, } I_T &= I_A + I_B + I_C \\
 &= 0.28 + 0.31 + 0.25 \\
 &= 0.84 \text{ A}
 \end{aligned}$$

Apparatus:

- 3 Resistor
- Voltmeter (Connect it parallel to the resistor)
- Ammeter (Connect it in series to the resistor)
- Wires
- Power source

Method:**Series:**

1. Connect the circuit as given in diagram 1.
2. Measure the potential difference of each resistors by connecting the voltmeter in parallel
3. Observe that the total voltage of the resistor is the same as the voltage of the power source
4. Measure the current through the resistor by connecting the ammeter in series before the respective resistor
5. Observe that all the currents are the same.
6. Repeat the measurements to make sure the result is reliable

Parallel:

1. Connect the circuit as given in diagram 3
2. Measure the potential difference of each resistors by connecting the voltmeter in parallel
3. Observe that the potential drop between the resistors are all the same
4. Measure the current through the resistor by connecting the ammeter in series before the respective resistor
5. Observe that the total current of the resistor is the same as the current of the power source.
6. Repeat the measurements to make sure the result is reliable

Results

Series		
VR1	VR2	VR3
IR1	IR2	IR3

Parallel		
VR1	VR2	VR3
IR1	IR2	IR3

Discussion:

- Which one is better (in connecting normal load), series or parallel?
- Discuss about the effect of shading of one cell in a module and its impact to the overall performance of the photovoltaic module.

Experiment 3

The Optimum Incident Angle for a Solar Cell

Aim:

To determine the effect of different incident angle on the efficiency of the solar cell.

Abstract

All devices powered by solar cells are expected to operate under its maximum power. Hence, to achieve this purpose, regulators and maximum power point tracker have been used to find a point where the cells generate a maximum power as a product of current and voltage regarding a particular value of resistance.

In particular, the performances of solar cells are also determined by several external factors such as the angle of incidence of the striking light. The generated power of the cell is directly proportional to the cosine of the incident angle with respect to the normal of the surface.

Notes

Tilt Angle Effect On Output Power Of Solar Cell

As a solar panel is tilted through various angles the current output varies. Figure 1 below shows how the angle of incidence can affect a solar cell output when the sunlight is directly above the solar panel at 0 degrees.

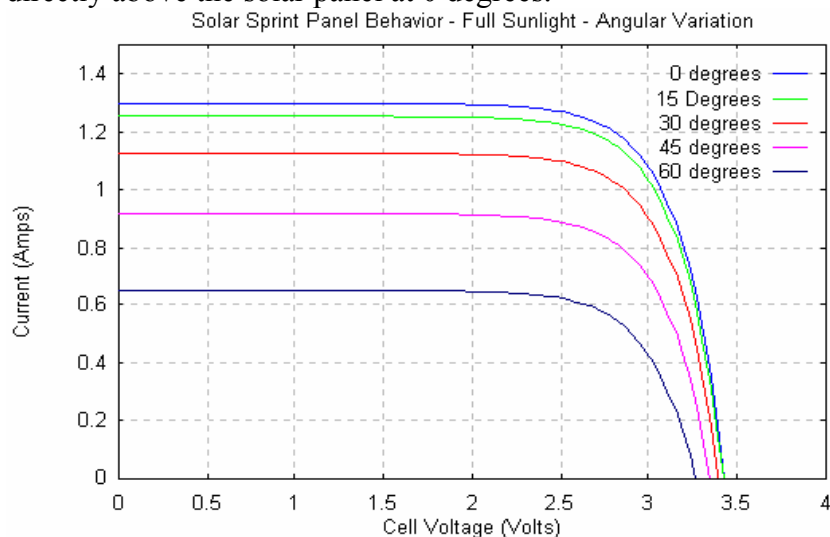

Figure 1: Solar cell output variation with tilt angle, from www.chuck-wright.com

Lambert's Law of Illumination states that the illumination of a surface is proportional to the cosine of the angle between the incident light rays and the normal to the surface (Solar Cells: Resource for the Secondary Science Teacher). Taking note that at a constant intensity of radiation from the sun, a cosine waveform will be produced with power as a function of angle. It is the reduction in surface area that is presented to the constant intensity that allows the shape of the cosine to be developed with the peak situated at perpendicular positions to the surface of the solar cell.

Equipment:

- solar cell
- Protractor
- light source
- Power source.
- Multimeters

Method:**Set up experiment 2**

1. Set the equipments as shown in Figure above. Set the resistor of the variable resistor to a specific value.
2. Place the solar cells at 0° which is defined as the angle where the frontal surface of the cell is directly facing the light source.
3. Measure the voltage and the current produced using multimeters. Record these values in a table.
4. Calculate the power produced by multiplying the voltage (V) by a corresponding value of current (I). Record these calculations in a table.
5. Repeat step 3 for different angles, namely -90° , -80° , -70° , -60° , -50° , -40° , -30° , -20° , -10° , 10° , 20° , 30° , 40° , 50° , 60° , 70° , 80° , 90° .
6. Note that the positive sign represents the clockwise rotation that is to the right with respect to 0° . On the other hand, the negative sign represents the anticlockwise rotation that is to the left with respect to 0° .
7. Plot the graph of the power produced as a function of the angle.
8. By observing the shape of the graph, determine the general relationship of the power and the angle.

Results:

Incident Angle (degrees)	Current (mA)	Voltage (V)	Power (mW)
90	0.545	2.14	1.1663
80	0.612	2.39	1.46268
70	0.728	2.85	2.0748

60	0.883	3.46	3.05518
50	1.02	3.99	4.0698
40	1.15	4.57	5.2555
30	1.236	4.85	5.9946
20	1.29	5.06	6.5274
10	1.315	5.15	6.77225
0	1.324	5.19	6.87156
-10	1.32	5.16	6.8112
-20	1.28	5.09	6.5152
-30	1.233	4.84	5.96772
-40	1.117	4.64	5.18288
-50	1.057	4.15	4.38655
-60	0.903	3.58	3.23274
-70	0.773	3.03	2.34219
-80	0.616	2.41	1.48456
-90	0.546	2.13	1.16298

Example of Power Calculation

For angle = 0

Power = Voltage \times Current

$$= 5.19 \times 1.324 = 6.87156\text{mW}$$

Other values of power were calculated in a similar manner.

Below is the graph plotting the experimental data with a cosine curve showing that the power can be worked out using the cosine curve. The equation of the cosine curve will be in the form:

$$P = A \cos \theta$$

Where P is the power attained, A is the product of incoming intensity, area of solar cell and its efficiency (i.e. the power attained when the light source is perpendicular to cell.), and θ is the angle of the light source from the normal.

Graph - Power vs Angle

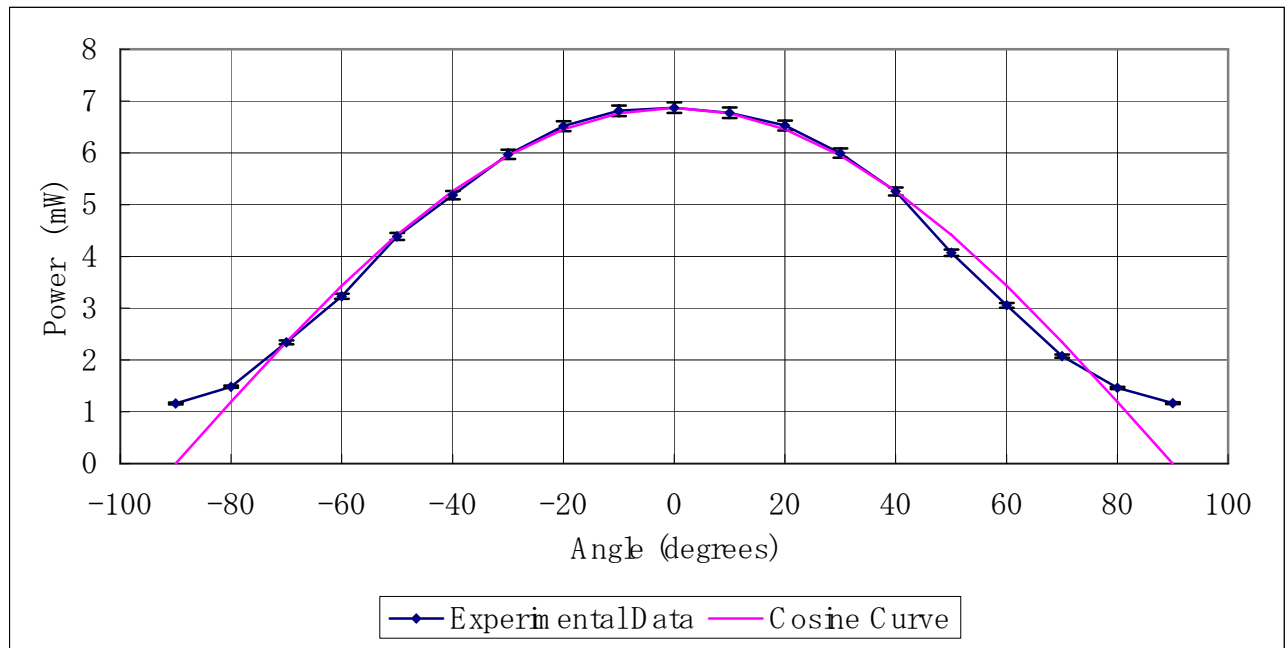

Optimum Angle = _____

Discussion:

It can be clearly seen from graph 2 that the power is generated as a function of the cosine of the angle. This kind of relationship is supported by the fact that the graph is vertically symmetric for positive (clockwise) and negative (anticlockwise) angles in which obviously represents the characteristic of cosine function of an angle.

In particular, the power is directly proportional to the cosine of the angle which is inversely proportional to the value of the angle itself. The greater the incident angle, the less power produced.

However, this cosine relationship is only valid for range of angles between -90° up to 90° . This is because in these angles, the frontal surface of the solar cell is still capable of capturing the light from the light source. However, if the graph is continued further beyond this range, the value of the power will not be zero as there is still a source of diffusion light coming from the background light.