

Marias Fair

Showmanship (Pre-Junior)

Show Date: July

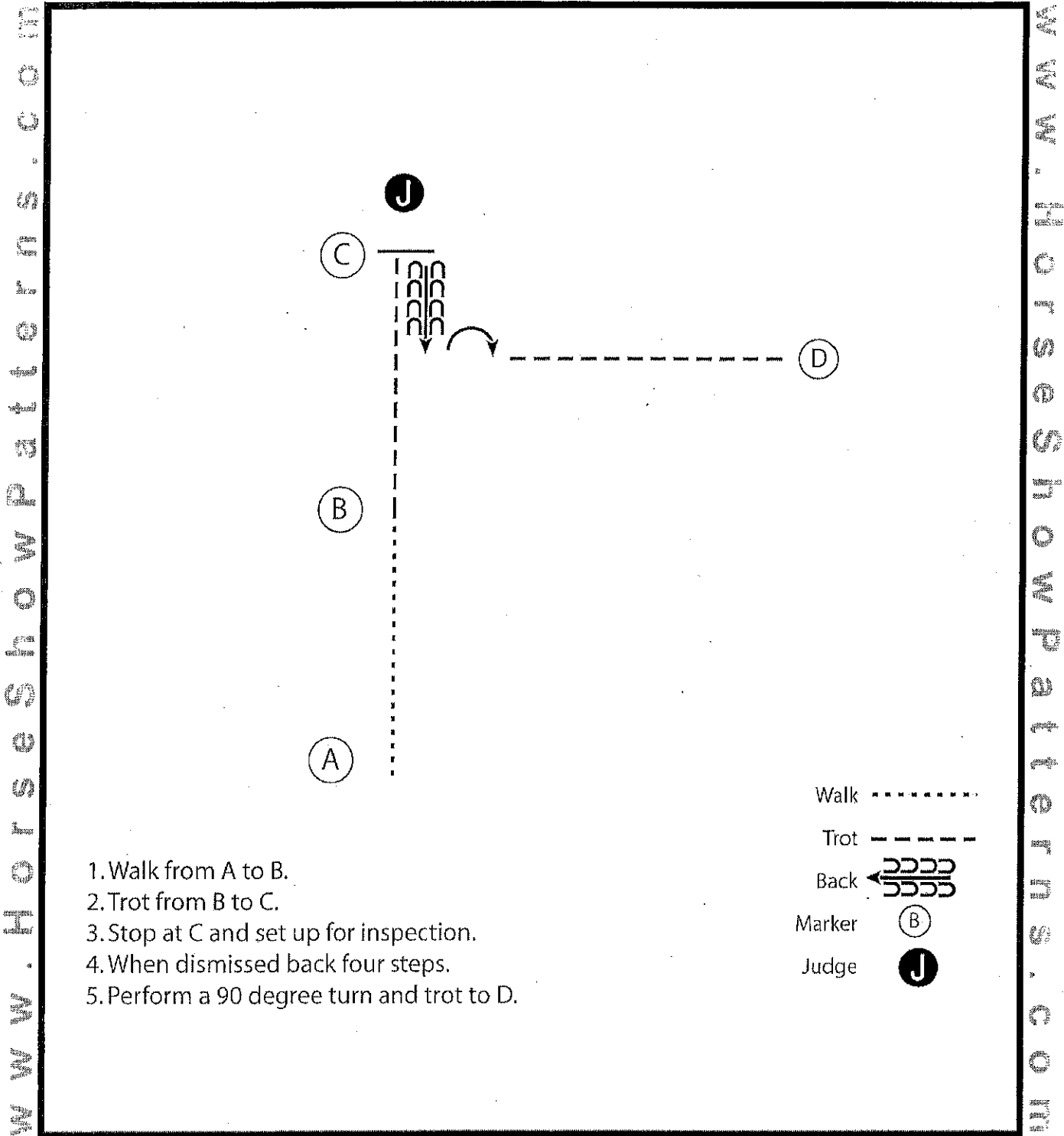

1. Walk from A to B.
2. Trot from B to C.
3. Stop at C and set up for inspection.
4. When dismissed back four steps.
5. Perform a 90 degree turn and trot to D.

Walk
Trot - - - - -
Back ← SSSSS
Marker (B)
Judge (J)

[S/2-7]

Pattern Provided by:
Horse Committee

Marias Fair

Showmanship (Junior)

Show Date: July

W W W . H O R S E S H O W P A T T E R N S . C O M

W W W . H O R S E S H O W P A T T E R N S . C O M

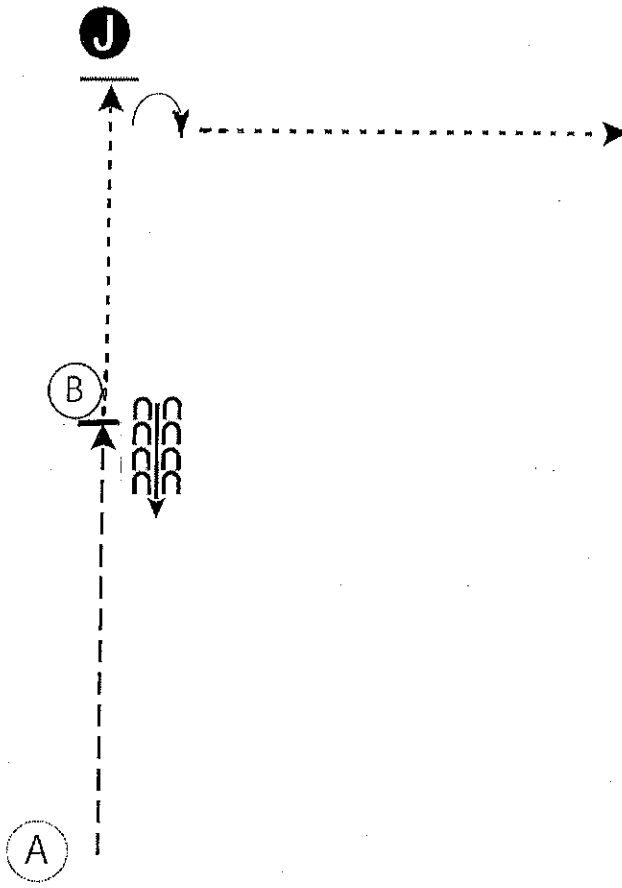



1. Be ready at A.
2. Walk to B. At cone B stop and back 5 steps.
3. Continue to judge, picking up a trot at cone B.
4. Trot to the judge. Stop and set up for inspection.
5. When dismissed, perform a 90 degree turn and trot to the line up or follow the instructions of the ring steward.

Walk 

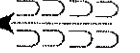
Trot 

Back 

Marker 

Judge 

[S/ 1-17a]

Pattern Provided by:
Horse Committee

Marias Fair

Showmanship (Senior)

Show Date: July

W W W . H O R S E S H O W P A T T E R N S . C O M

W W W . H O R S E S H O W P A T T E R N S . C O M

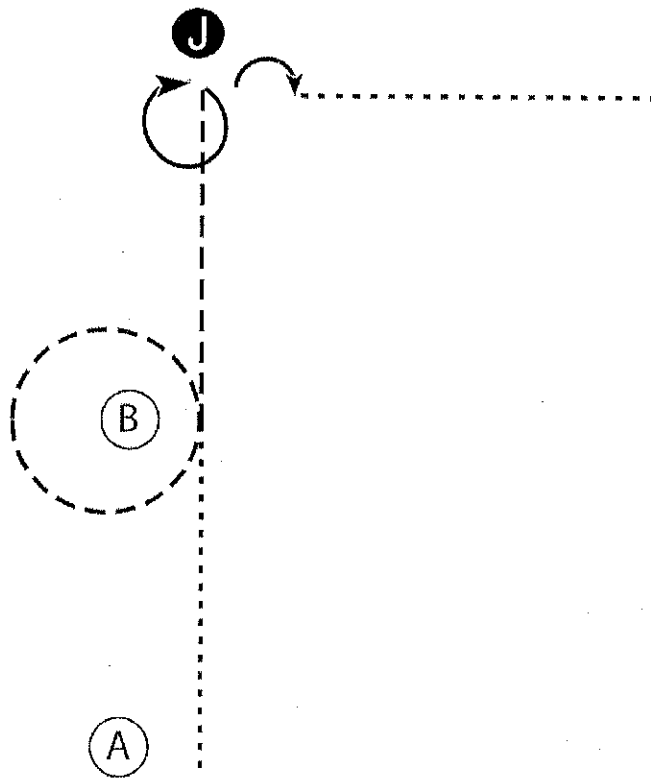

1. Walk from A to B.
2. At B trot. Trot a circle around B and continue to the Judge.
3. Stop and perform a 360 degree turn. Set up for inspection.
4. When dismissed perform a 90 degree turn.
5. Walk straight away from the Judge.

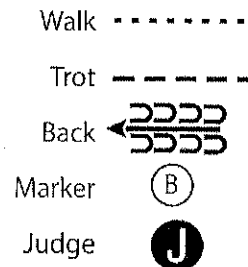

[S/2-8]

Pattern Provided by:
Horse Committee

Marias Fair

Showmanship (Yearling At Halter)

Show Date: July

W W W . H O R S E S H O W P A T T E R N S . C O M

W W W . H O R S E S H O W P A T T E R N S . C O M

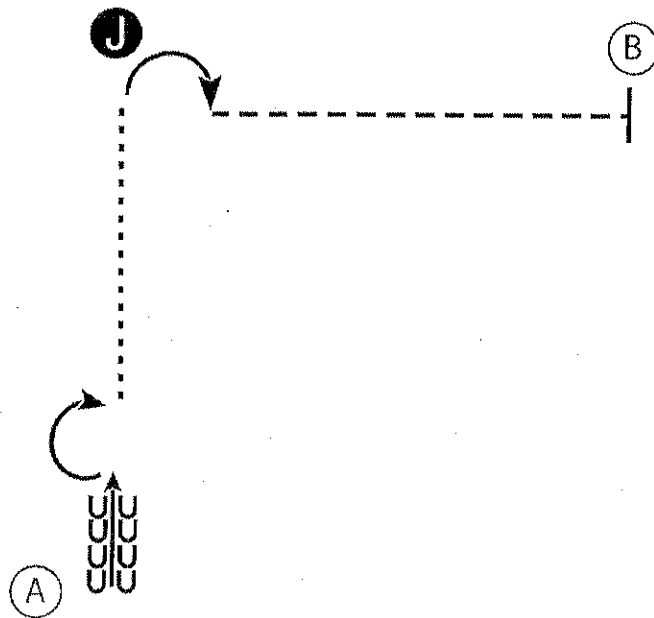

1. Back 4 steps at A.
2. Perform a 180 degree turn.
3. Walk to the Judge and set up for inspection, picking up the left front foot upon the Judges' request.
4. When dismissed, perform a 90 degree turn and trot to B.
5. Stop at B and wait for instruction from your ring steward.

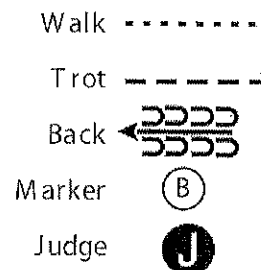

S/1-2b

Pattern Provided by:
Horse Committee

Western Horsemanship (Level 1)

Show Date:

www.horshowpatterns.com

www.horshowpatterns.com

1. Jog A to B
2. At B perform a figure eight, beginning to the right
3. Continue the jog from B to C
4. At C stop and back 4 steps

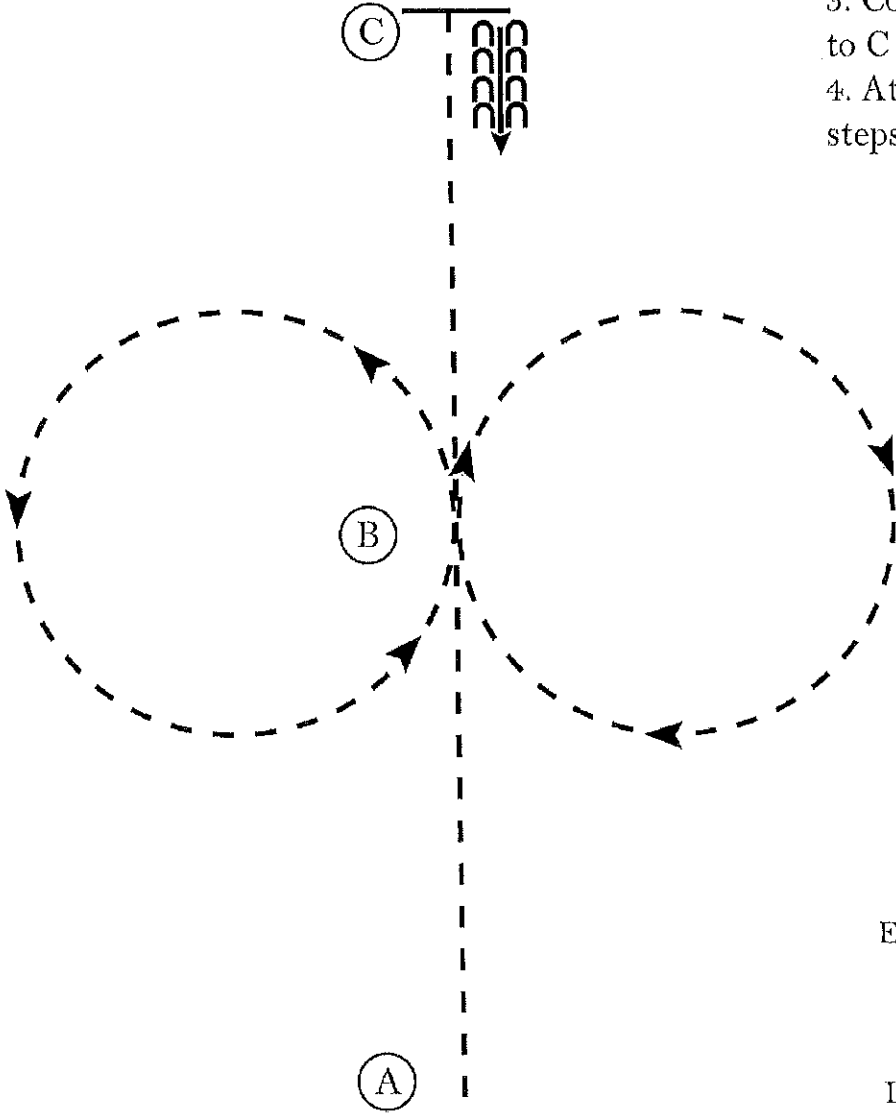

Walk
Jog	-----
Extended Jog	-----
Lope	
Leg Yield	
Lead Change	///
Back	CCCC ←←←←
Marker	(B)
Sidepass	←-----→

[WH/WT-5]

3/2013

Pattern Provided by:

Montana 4-H State Horse Committee

Marias Fair

Western Horsemanship (Level 2)

Show Date: July

www.HorseShowPatterns.com

www.HorseShowPatterns.com

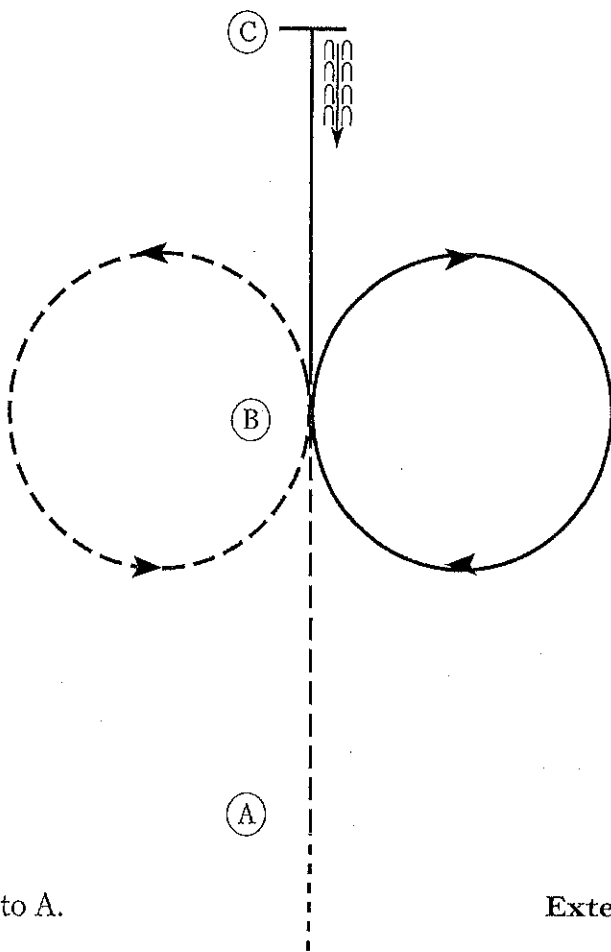

Be ready prior to A.

1. Walk to A.
2. Jog A to B.
3. At B jog a circle to the left.
4. At B lope a circle to the right on the right lead.
5. Continue the lope to C.
6. Stop at C and back approximately one horse length.

Walk	-----
Jog	- - - - -
Extended Jog	-----
Lope	—————
Leg Yield	
Lead Change	↘
Back	←←←←← ←←←←←
Marker	Ⓚ
Sidepass	←-----→

[WH/1-19]

Pattern Provided by:
Horse Committee

Marias Fair

Western Horsemanship (Level 3)

Show Date: July

www.HorseShowPatterns.com

www.HorseShowPatterns.com

Be ready at A.

1. Jog from A to B.
2. Lope a circle to the left on the left lead.
3. Stop at B.
4. Back one horse length at B.
5. Extend the jog to C.
6. Stop at C.

Follow the instructions of your ring steward.

Walk	-----
Jog	- - - - -
Extended Jog	-----
Lope	—————
Leg Yield	
Lead Change	↙
Back	←←←←←
Marker	⊙ B
Sidepass	←-----→

[WH/1-18]

Pattern Provided by:
Horse Committee

Western Horsemanship (Level 4)

Show Date:

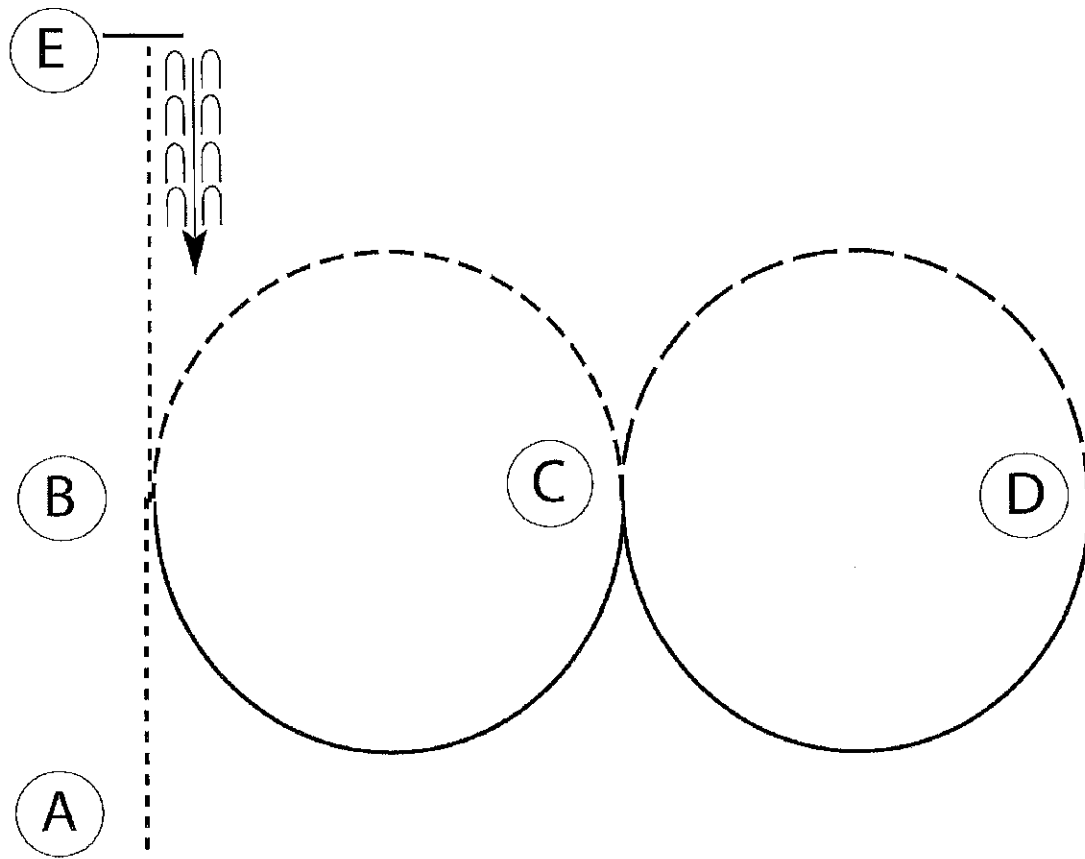

Be ready at A.

1. Walk A to B.
2. Jog a half circle to C.
3. Lope a half circle on the left lead to D.
4. Extend the jog in a half circle to C.
5. Lope a half circle on the right lead to B.
6. Walk to E.
7. Stop at E and back approximately one horse length.

Follow the instructions of your ring steward.

Walk
Jog	-----
Extended Jog	- - - - -
Lope	—————
Lead Change	
Back	
Marker	(B)

[WH/2-3]

3/2017

Pattern Provided by:

Montana 4-H State Horse Committee

www.horsethows.com

www.horsethows.com

Western Horsemanship (Level 5)

Show Date:

www.horsethows.com

www.horsethows.com

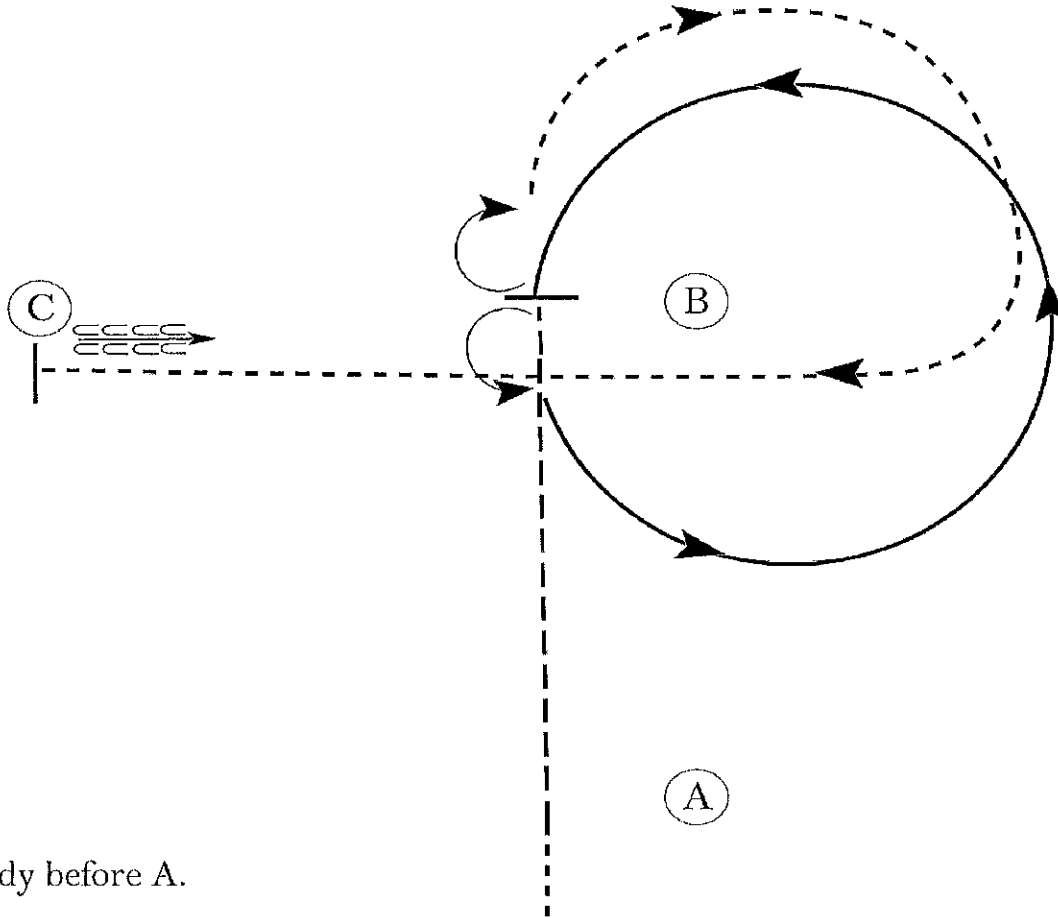

Be ready before A.

1. Walk to A.
2. Jog to B. Stop and turn 180 degrees left.
3. Lope a circle to the left on the left lead.
4. Stop at B. Turn 180 degrees to the right.
5. Perform an extended jog circle to the right.
6. Slow to the jog at B.
7. Jog to C.
8. Stop at C and back approximately one horse length.

Follow the instructions of your ring steward.

Walk	-----
Jog	- - - - -
Extended Jog	-----
Lope	—————
Leg Yield	
Lead Change	↘
Back	←←←←←
Marker	⊙ B
Sidepass	←-----→

[WH/3-37]

3/2013

Pattern Provided by:

Montana 4-H State Horse Committee

Western Horsemanship (Level 6)

Show Date:

www.horsheshowpatterns.com

www.horsheshowpatterns.com

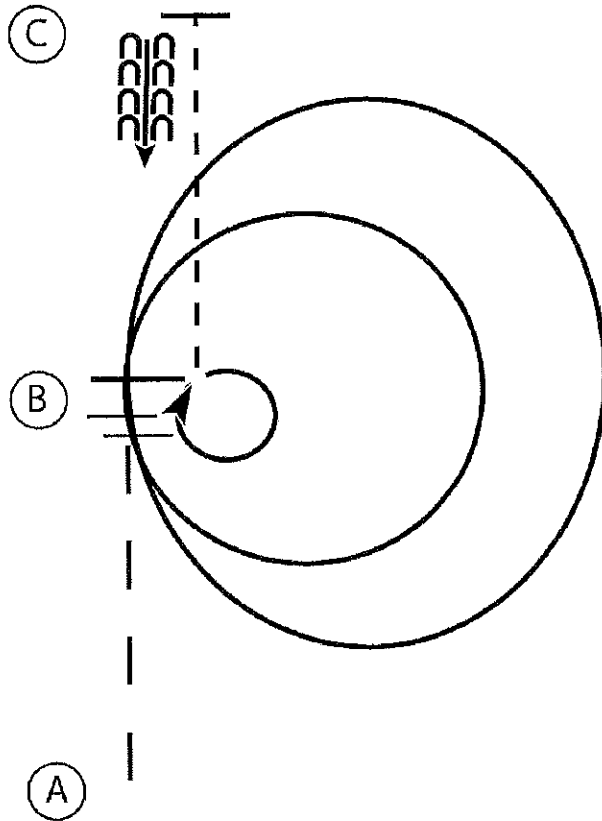

1. Extend the jog A to B
2. At B lope a circle to the right on the left lead
3. At B change leads and continue with speed in a circle to the right
4. Stop at B and perform a 360 to the right
5. Jog B to C
6. Stop at C and back 4 steps

Walk
Jog	-----
Extended Jog	—————
Lope	—————
Leg Yield	
Lead Change	↖ ↗
Back	←←← ←←←
Marker	(B)
Sidepass	←-----→

[WH/3-14]

3/2013

Pattern Provided by:

Montana 4-H State Horse Committee

Marias Fair English Horsemanship (Level 1)

Show Date:

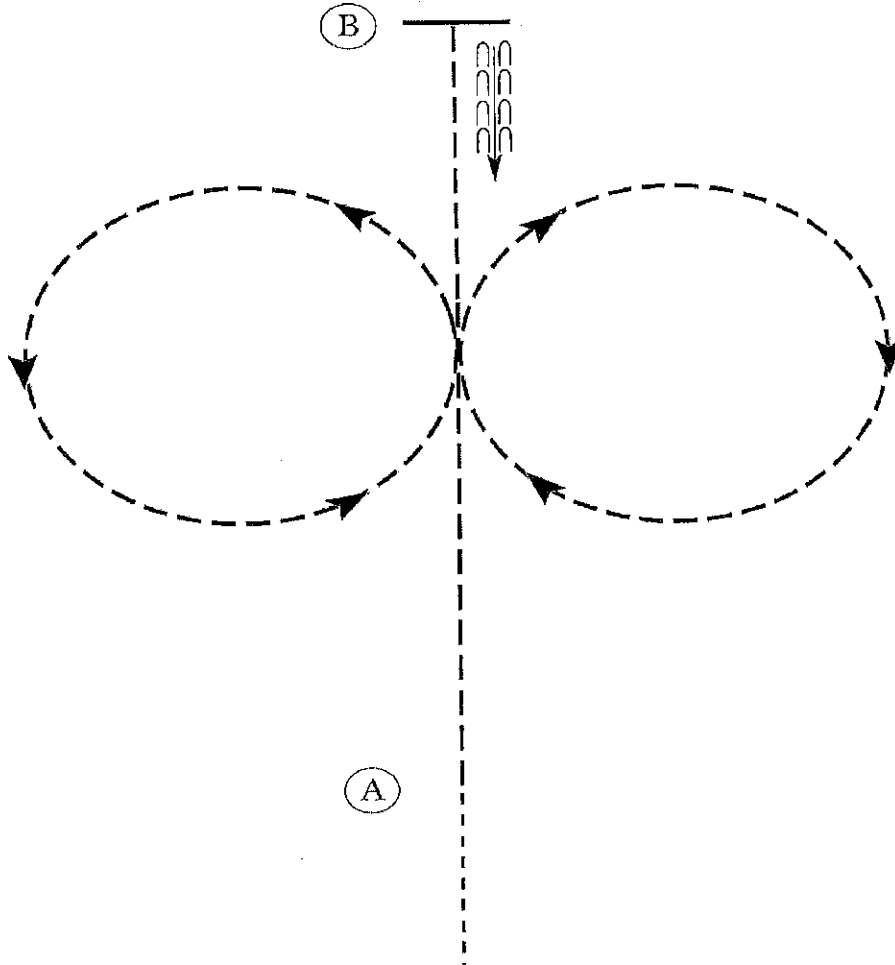

1. Walk to A.
2. At A sitting trot towards B.
3. When halfway to B posting trot circle to the right followed by a posting trot circle to the left.
4. Continue the posting trot to B.
5. At B stop and back approximately one horse length.

Walk	-----
Trot	- - - - -
Extended Trot	-----
Canter	-----
Leg Yield	
Lead Change	↙ ↘
Back	←←←←←
Marker	Ⓚ
Sidepass	←←←←←
Hand Gallop	-----

[HSE/WT-4]

3-2013

Pattern Provided by:

Montana 4-H State Horse Committee

www.horsemanshippatterns.com

www.horsemanshippatterns.com

Marias Fair

English Horsemanship (Level 2)

Show Date: July

www.HorseShowPatterns.com

www.HorseShowPatterns.com

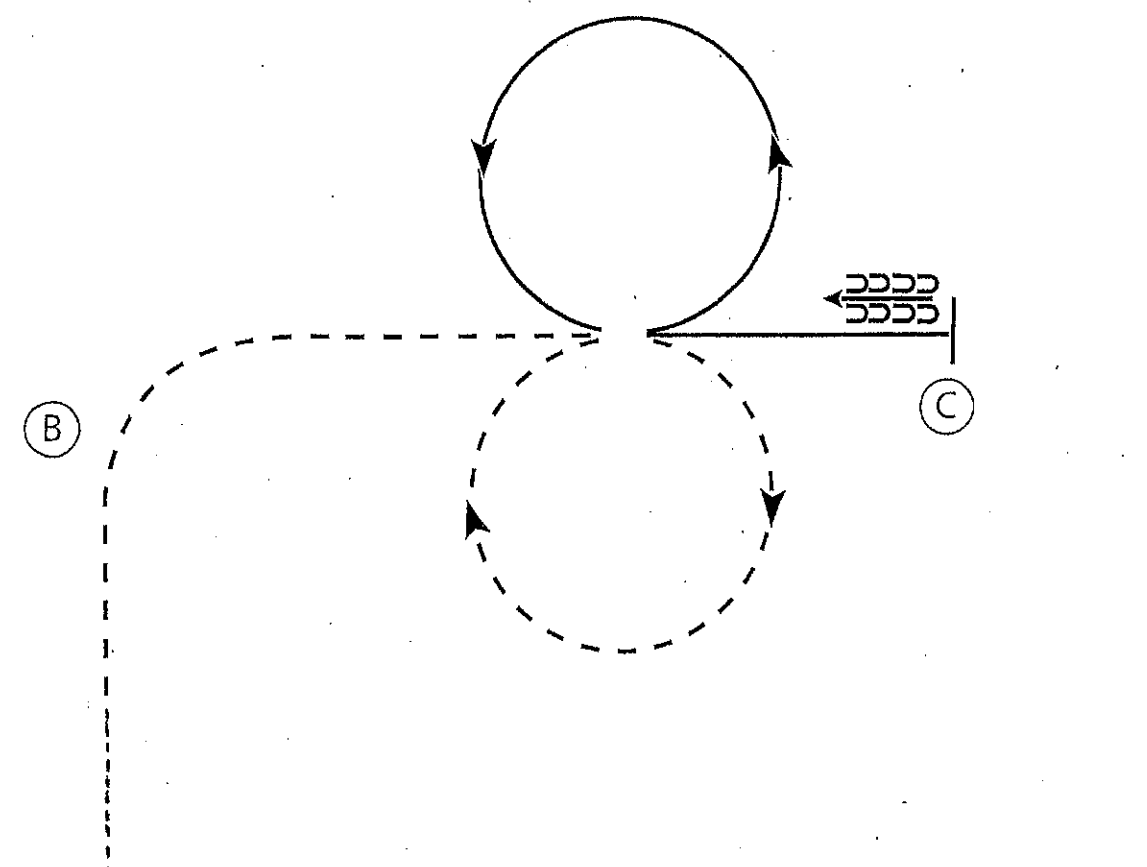

- (A) 1. Begin at A. Walk halfway to B, then pick up sitting trot to B.
2. At B posting trot towards C on the left diagonal
3. Before C posting trot a circle to the right followed by a canter circle to the left on the left lead, continue to C
4. At C stop and back four steps

- Walk
- Trot - - - - -
- Extended Trot - - - - -
- Canter _____
- Leg Yield |||||
- Back ←←←←←
- Marker (B)
- Sidepass ←- - - -→

[HSE/1-10]

Pattern Provided by:
Horse Committee

English Horsemanship (Level 3)

Show Date:

www.HorseShowPatterns.com

www.HorseShowPatterns.com

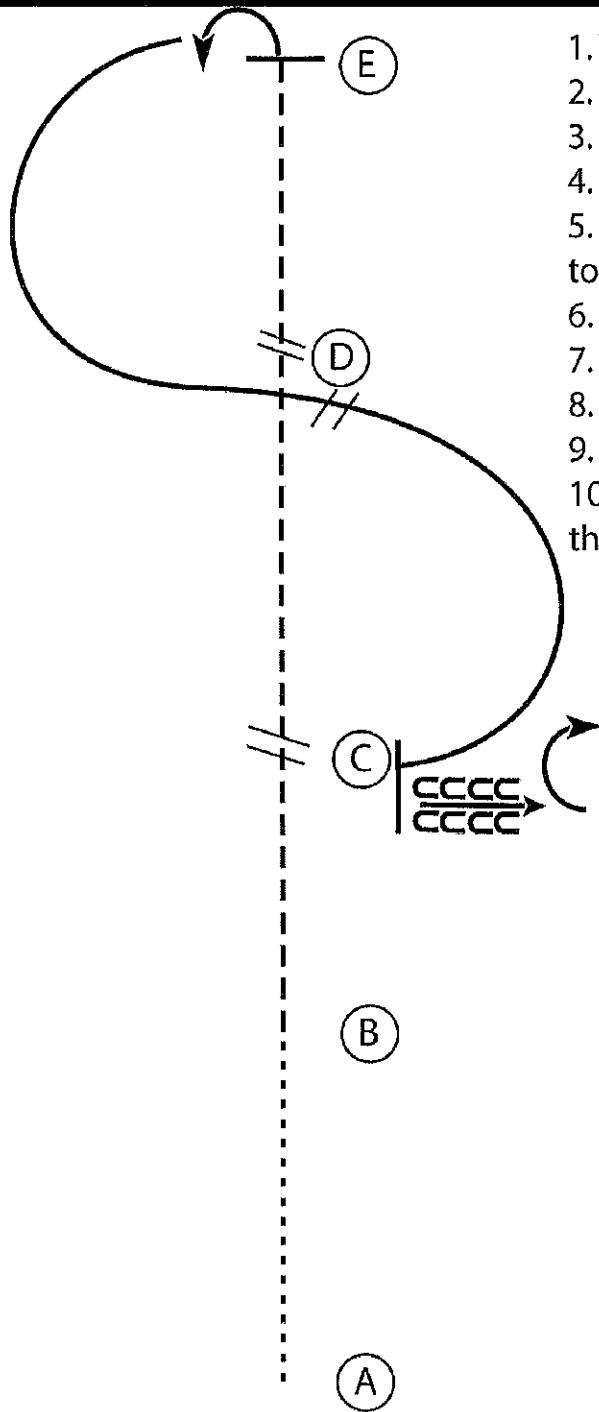

1. Walk A to B
2. Posting trot on the right diagonal B to C
3. Posting trot on the left diagonal C to D
4. Posting trot right diagonal D to E
5. Stop at E and perform a 90 degree turn to the left
6. Canter a half circle on the left lead to D
7. At D perform a lead change
8. Canter a half circle on the right lead to C
9. At C stop and back 4 steps
10. Perform a 90 degree turn to the right on the forehand

Walk
Trot	- - - - -
Extended Trot	- - - - -
Canter	—————
Leg Yield	
Lead Change	↘ ↙
Back	←←←← →→→→
Marker	(B)
Sidepass	←——→

[HSE/3-4]
3-2013

Pattern Provided by:

Montana 4-H State Horse Committee

ENGLISH HORSEMANSHIP IV

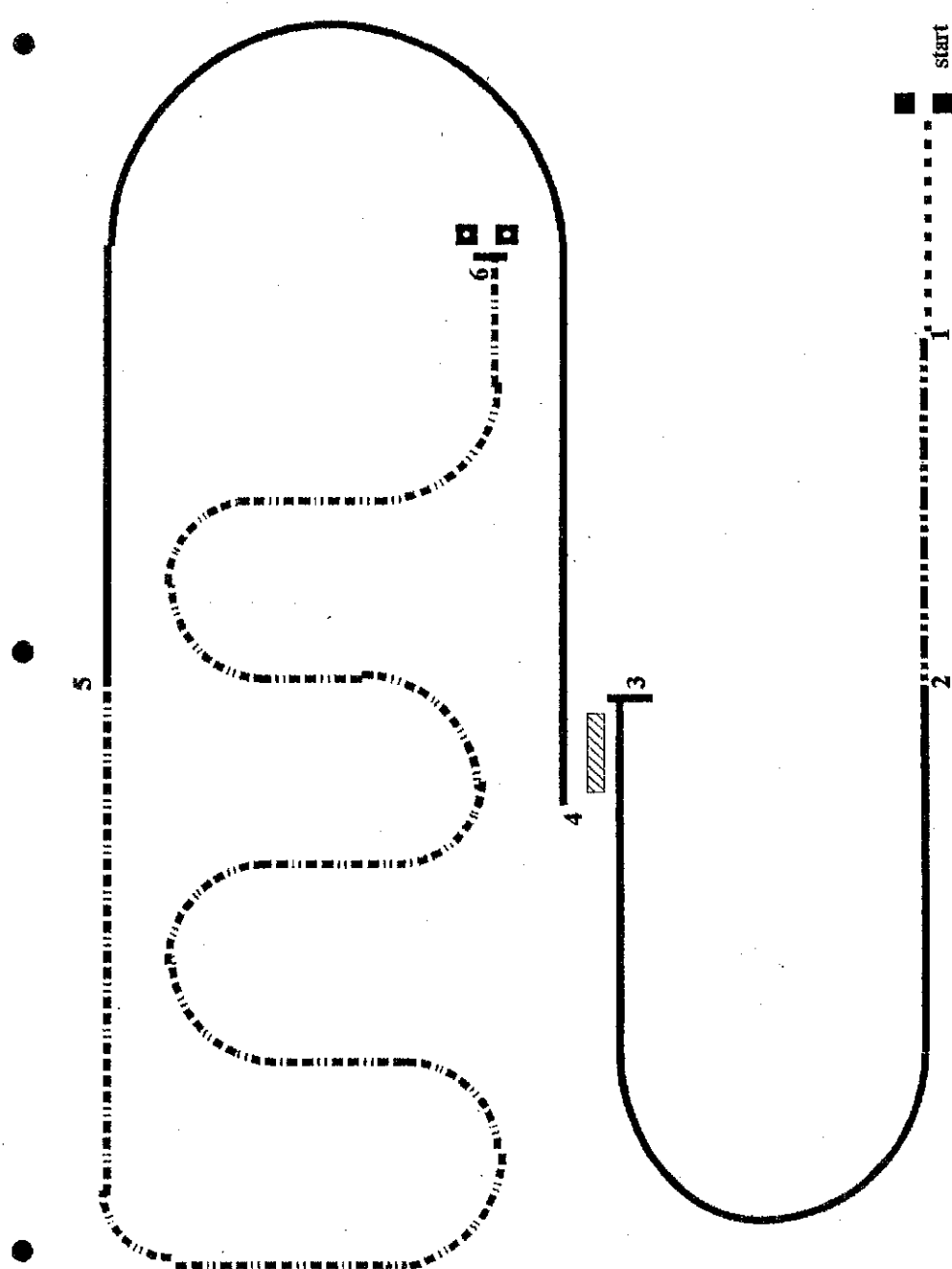

1. Complete 90° forehand pivots right and left. Walk to # 1.
2. Sitting trot to # 2. Pick up right lead to # 3. Halt.
3. Back 6 steps. From # 4 pick up left lead to # 5.
4. At # 5 break to trot, continue around end into serpentines, riding correct diagonals, to # 6.
5. At # 6 come to a halt. Complete 90° hindquarter pivots right and left.
6. Trot to judge for inspection.

Marias Fair

English Horsemanship (Level 6)

Show Date: July

www.HorseShowPatterns.com

www.HorseShowPatterns.com

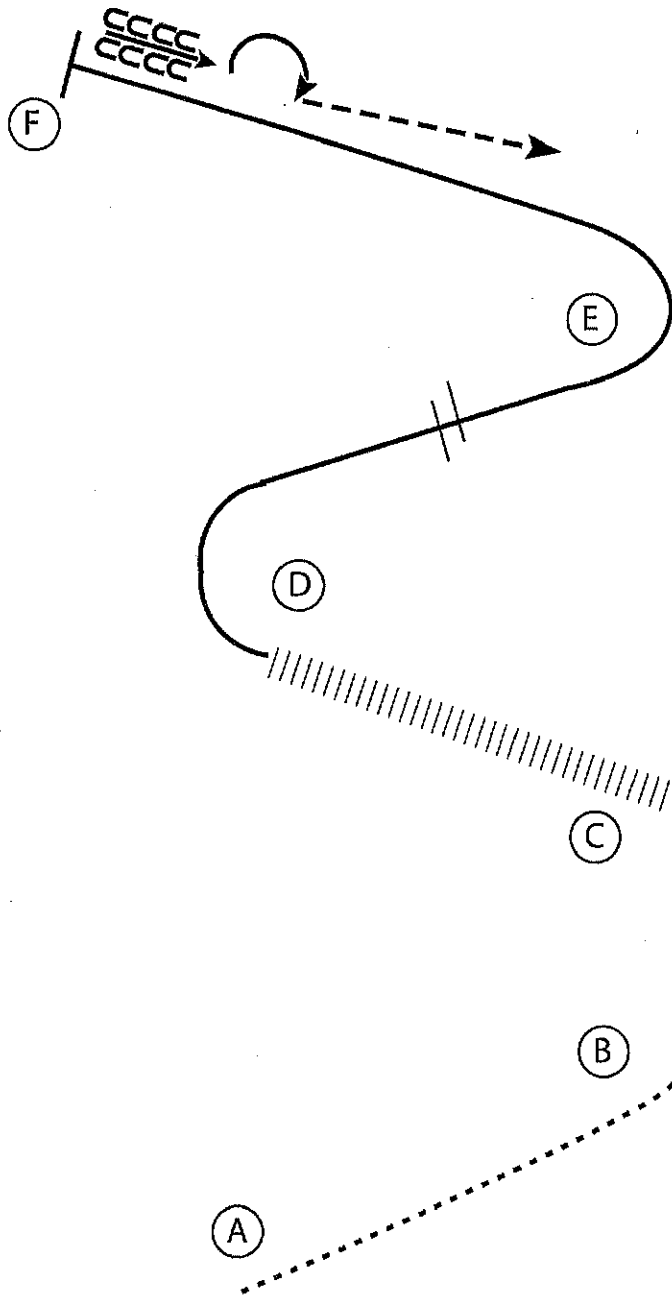

1. Walk A to B
2. Sitting trot B to C
3. Leg yield C to D
4. At D canter on the right lead towards E
5. When halfway to E perform a lead change and continue at the canter around E to F
6. At F stop and back 4 steps
7. Perform a 180 degree turn to the right on the forehand
8. Posting trot on the left diagonal to exit

Walk
Trot	- - - - -
Extended Trot	— — — — —
Canter	—————
Leg Yield	
Lead Change	↙ ↘
Back	←←←←
Marker	(B)
Sidepass	→ - - - - →

[HSE/3-13]

Pattern Provided by:
Horse Committee

Pre-Junior Trail

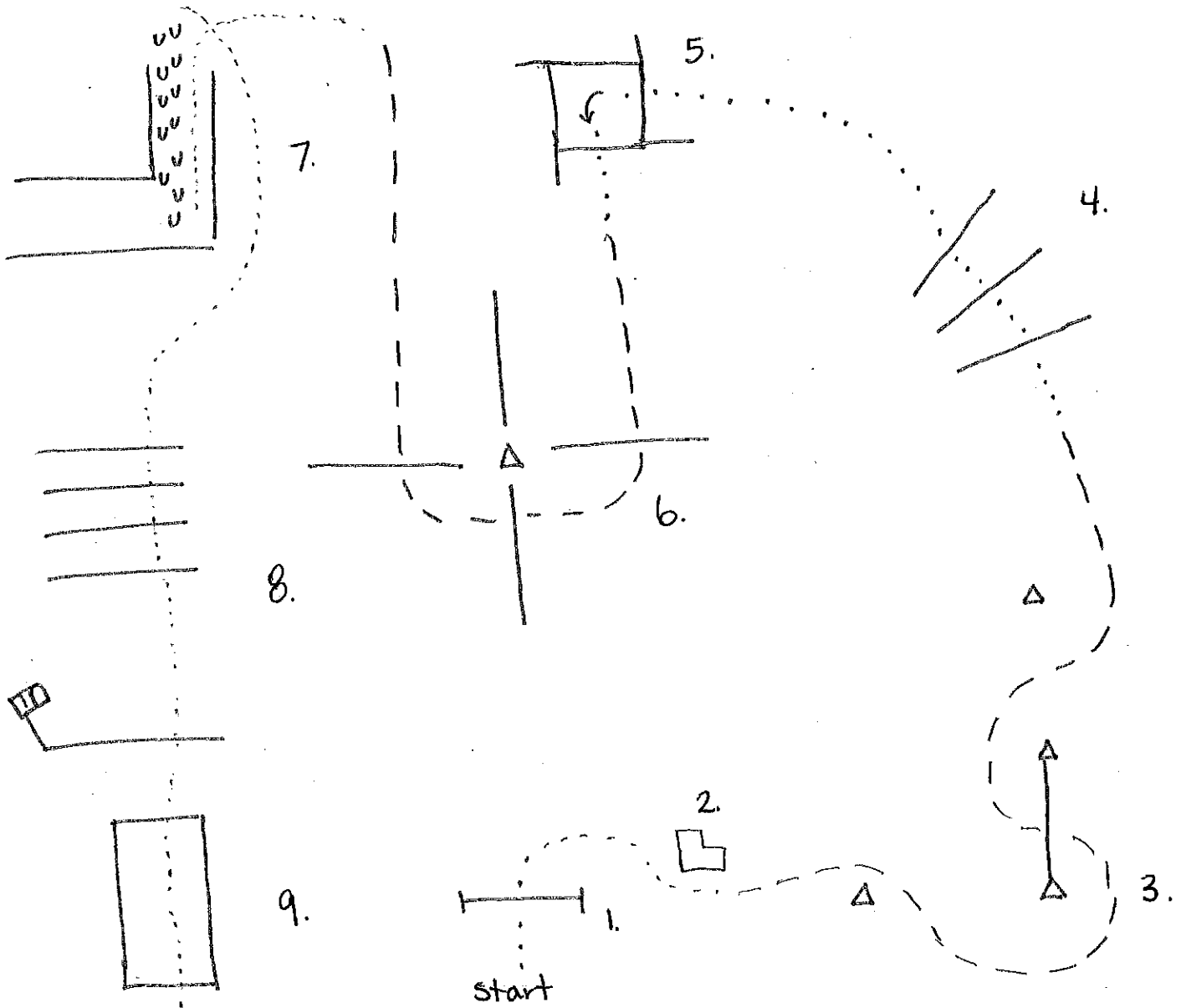

X Finish

(J)

1. Lead horse through gate, open + close
2. Mount at block, with assistance as needed
3. Jog serpentine through cones, over pole
4. Walk over poles
5. Walk into box, 90° to left
6. Walk out, jog over 3 spokes
7. Walk into chute, back out
8. Walk over poles
9. Walk over bridge

Intermediate Trail Junior

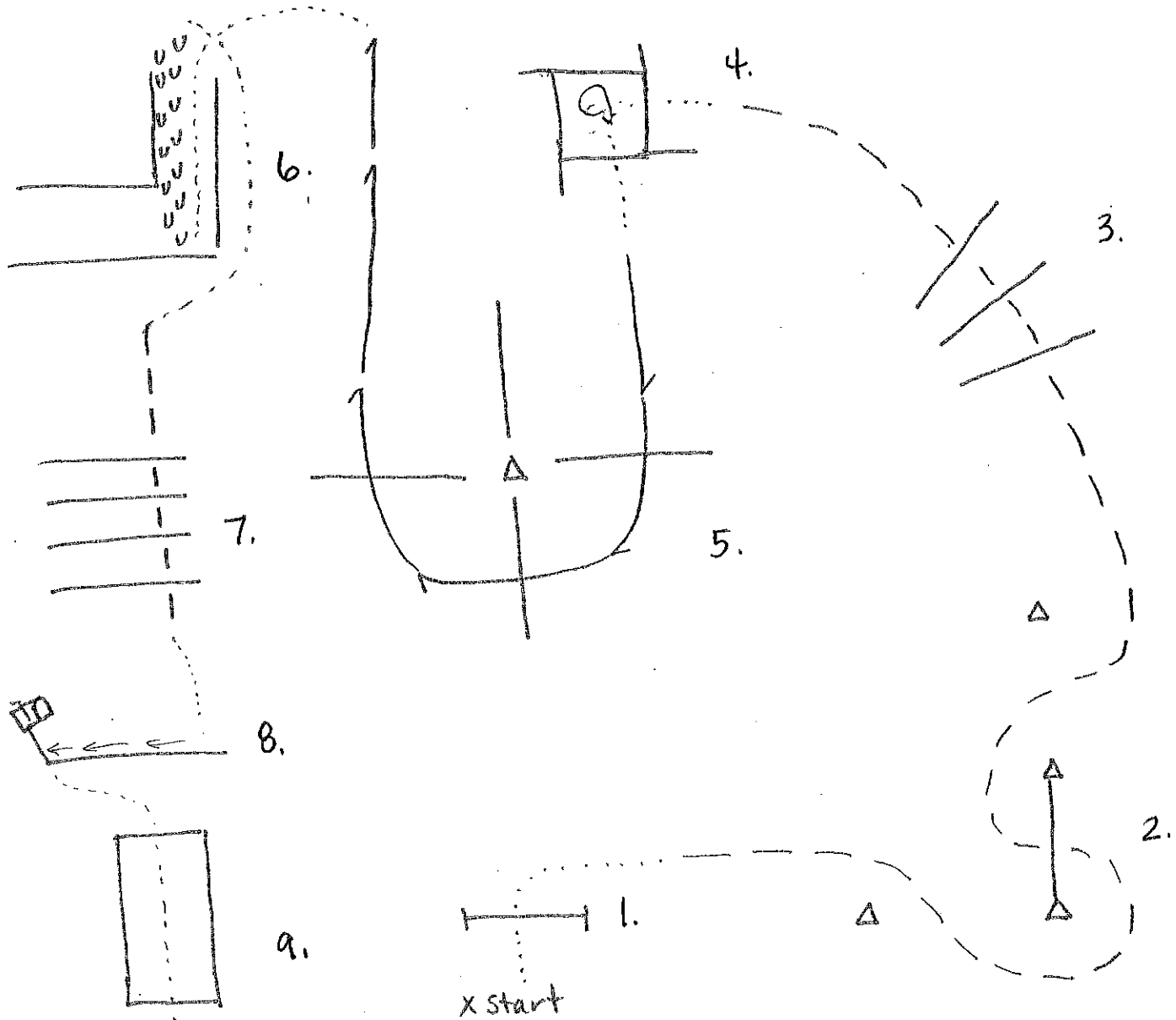

x Finish

(J)

1. Ride through gate, open and close
2. Jog through serpentine, over pole
3. Jog over poles
4. Walk into box, 270° turn to right, exit
5. Lope over 3 spokes, right lead
6. Walk into chute, back out
7. Jog over poles
8. Walk over pole, sidepass to right
open mailbox, close
9. Walk over bridge

Senior Trail

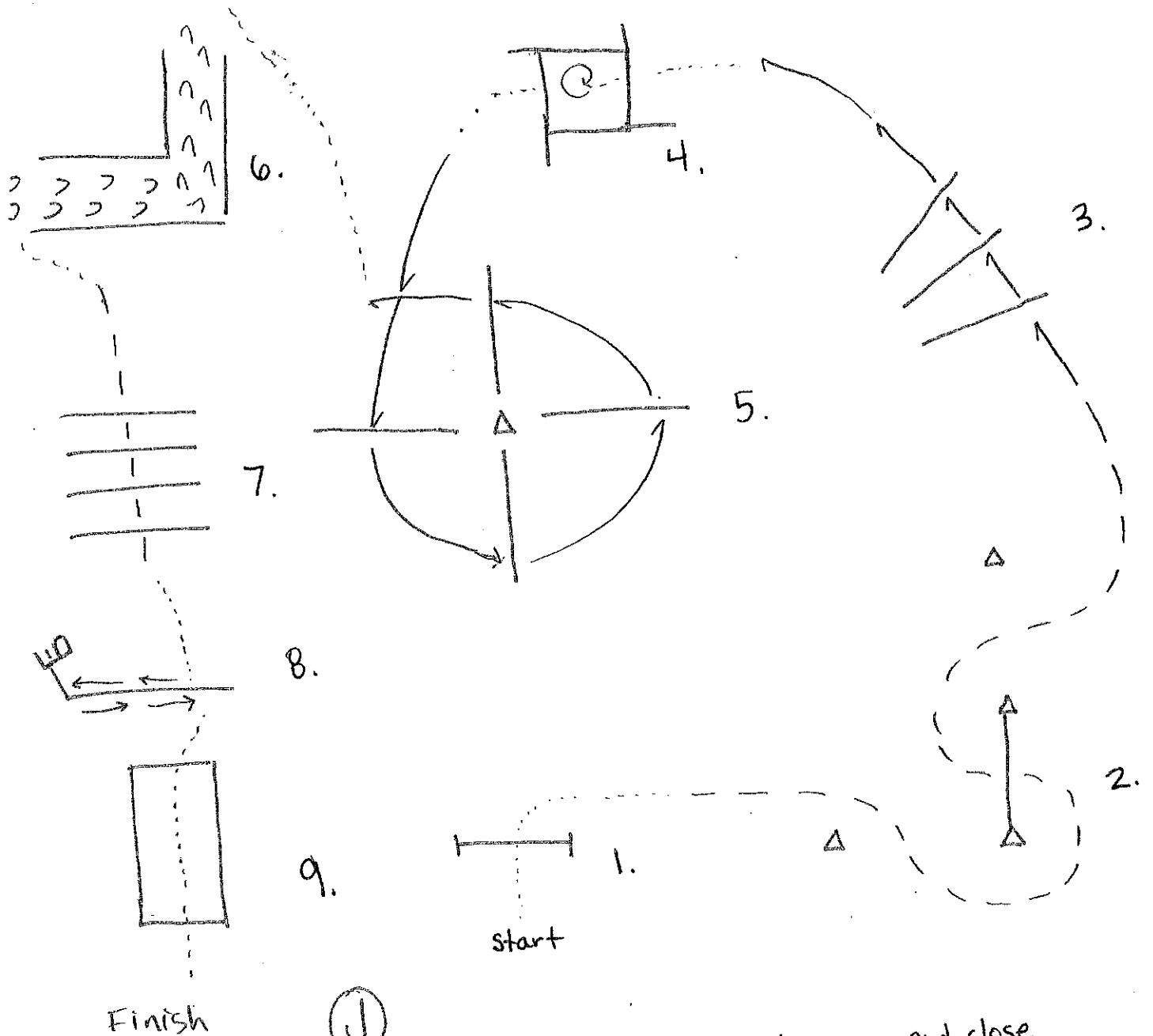

(J)

1. Ride through gate, open and close
2. Jog through serpentine, over pole
3. Lope, left lead, over poles
4. Walk into box, 360° to right, exit
5. Lope over spokes - 4, left lead
6. Back through L-chute
7. Jog over poles
8. walk to pole sidepass right, open mailbox close, sidepass left
9. Walk over bridge, Finish

Yearling, In-hand trail

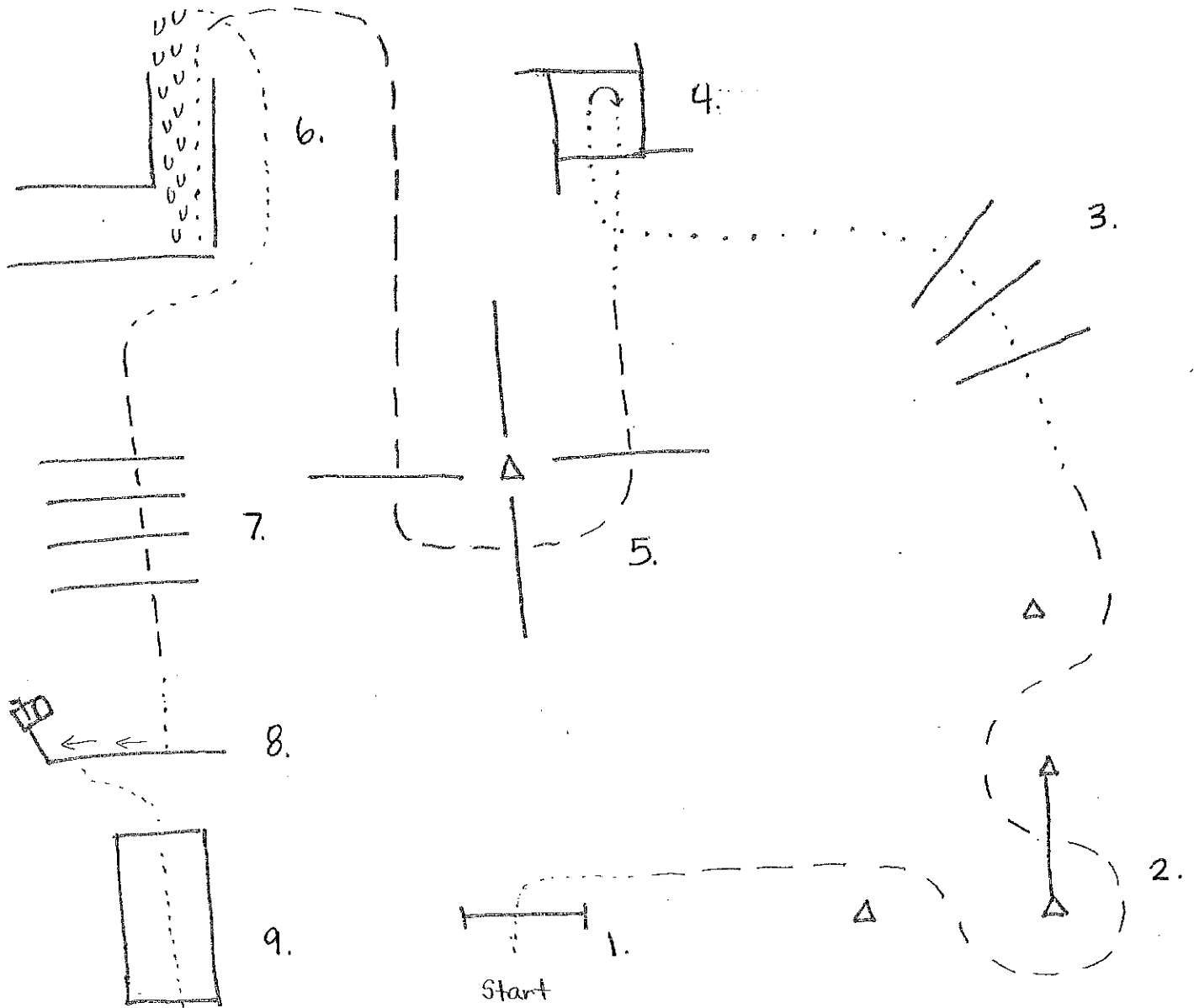

X Finish

(J)

1. Walk through gate, open & close
2. Jog through serpentine, over pole
3. Walk over poles
4. Walk into box, 180° to right, exit
5. Jog over spokes to right
6. Walk into chute, back out
7. Jog over poles
8. Walk over pole, sidepass to mailbox
9. Walk over bridge

Yearling, In-hand trail

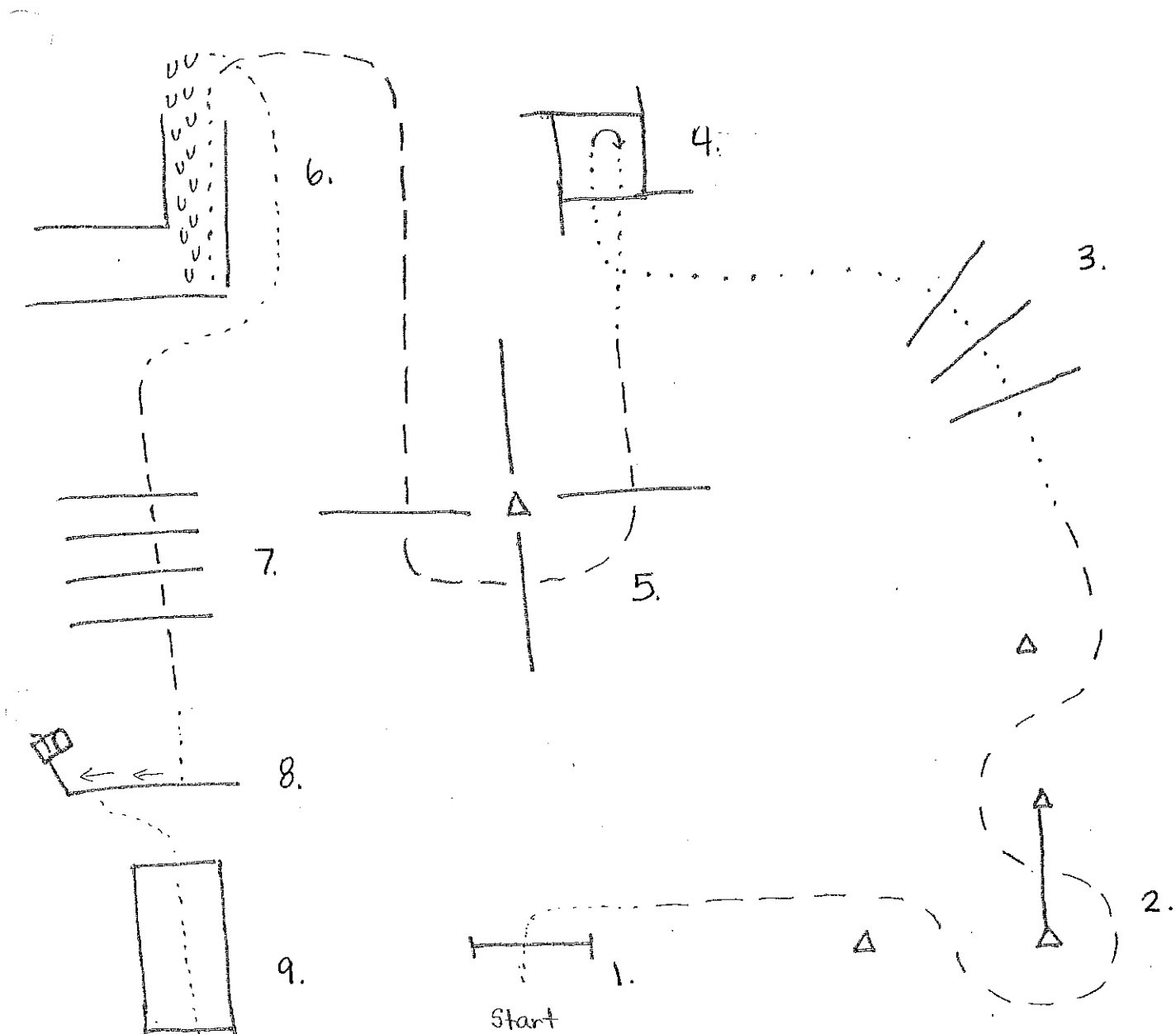

x Finish

(J)

1. Walk through gate, open & close
2. Jog through serpentine, over pole
3. Walk over poles
4. Walk into box, 180° to right, exit
5. Jog over spokes to right
6. Walk into chute, back out
7. Jog over poles
8. Walk over pole, sidepass to mailbox
9. Walk over bridge

**2-Year-Old
Colt to Maturity
Is Rail Work
(No Pattern)**

Marias Fair

3 Year Old Colt Project

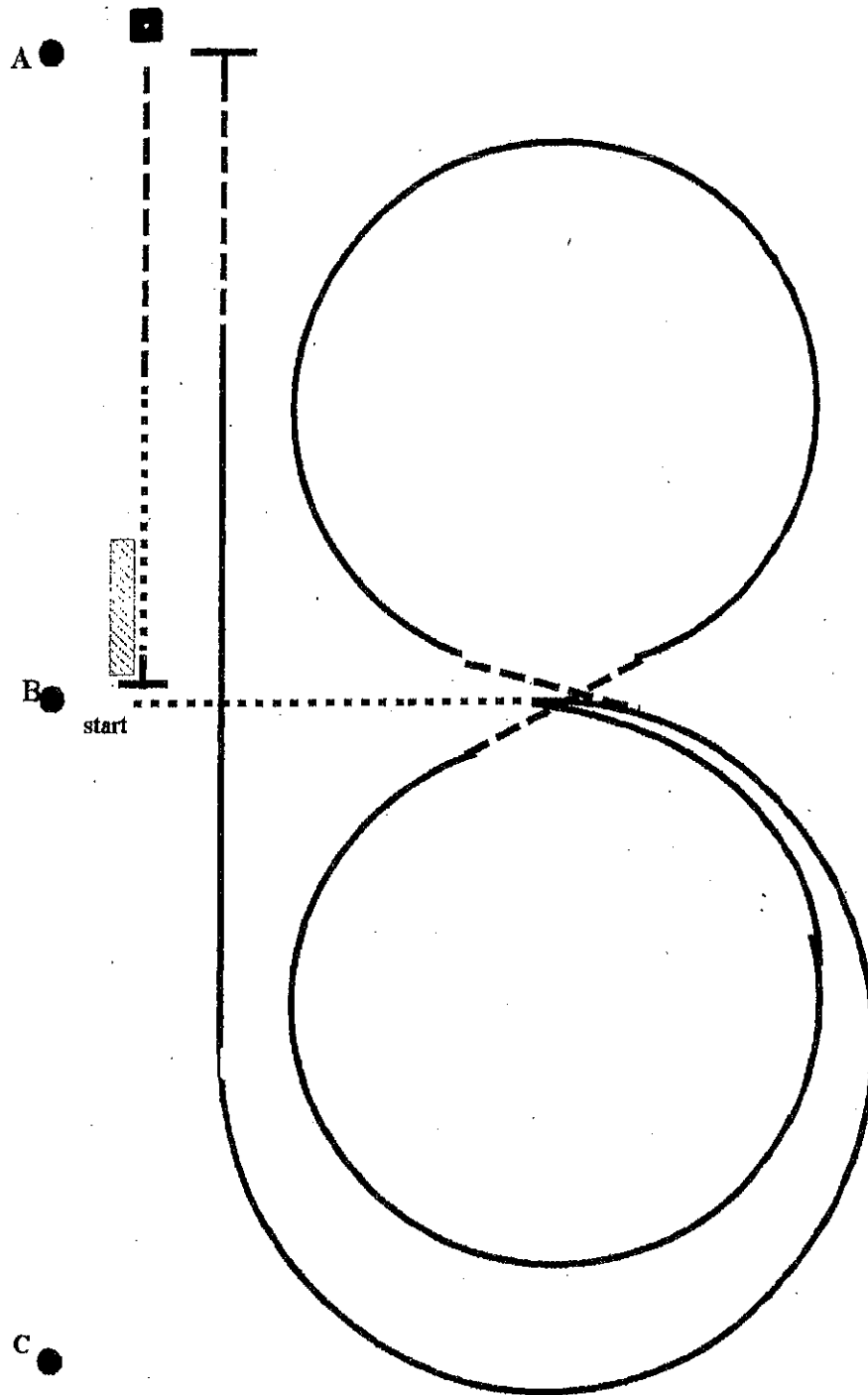

1. Walk to center. Pick up right lead and lope a circle.
2. Complete a simple lead change at center.
3. Lope a circle to the left with another simple lead change in the center.
4. Start right circle (don't close circle) but lope past center towards marker A. Break to jog.
5. Stop at marker A. Settle. Do a 180° hind quarter pivot to the left. Jog then slow to a walk and stop at marker B.
Back 10 steps.

4 Year Old Colt Project

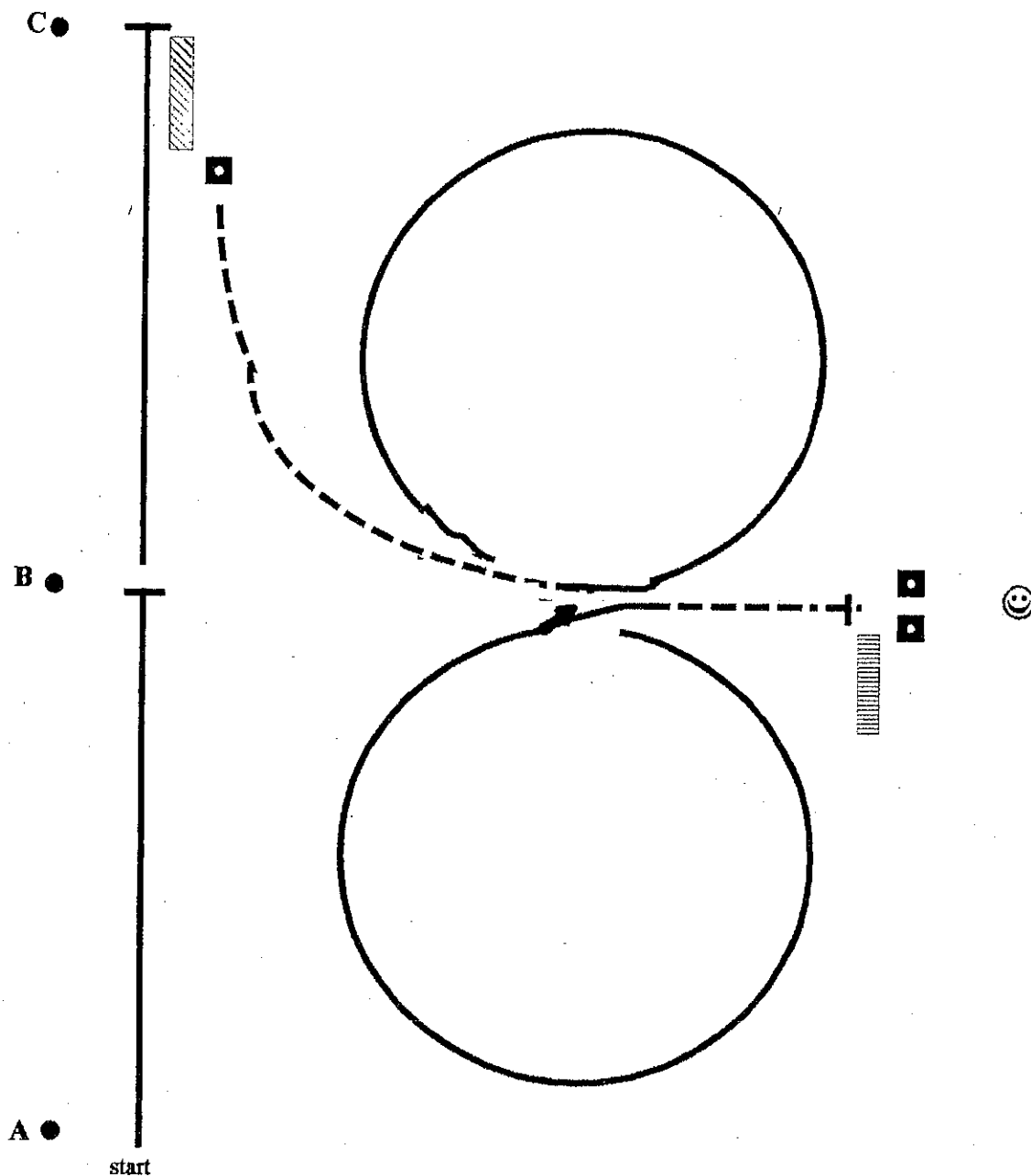

1. At marker **A** start lope in left lead. At marker **B** stop. Settle.
2. At marker **B** pick up right lead and lope to marker **C**. Stop. Settle. Back 10 steps. Do a 180° hindquarter pivot to the right.
3. Jog towards marker **B** picking up left lead to start figure 8. Execute a flying lead change at center.
4. After completing figure 8 break to jog. Jog towards judge. Stop. Settle. Sidepass right and left at least 6 ft. each way. Do a 360° hindquarter turn each way.

5 Year Old Colt Project

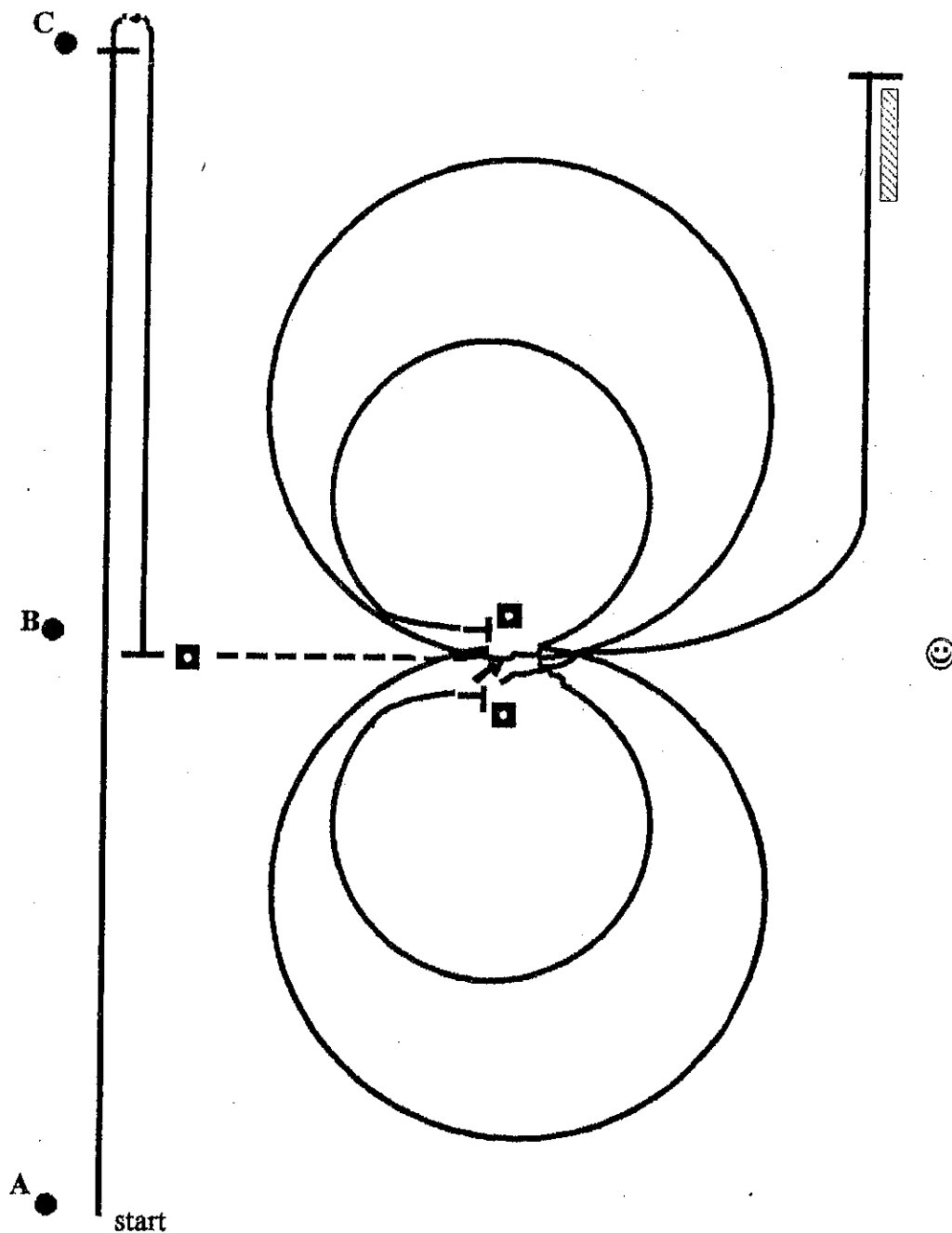

1. Starting at marker A lope on right lead to marker C, do a rollback, lope to marker B and stop.
2. At marker B do a 90° left hind pivot, then jog to center.
3. At center lope circle to left, close circle and stop. Do two 360° hindquarter spins left. Settle.
4. Lope circle to right, close circle and stop. Do two 360° spins right. Settle.
5. Start figure 8 to the left with flying lead change in center. Complete figure 8 and continue loping until even with marker C. Stop. Settle. Back 10 steps.

Colt To Maturity 2-year/Green Horse Level 1

Show Date:

w w . H o r s e s h o w P a t t e r n s . c o m

w w . H o r s e s h o w P a t t e r n s . c o m

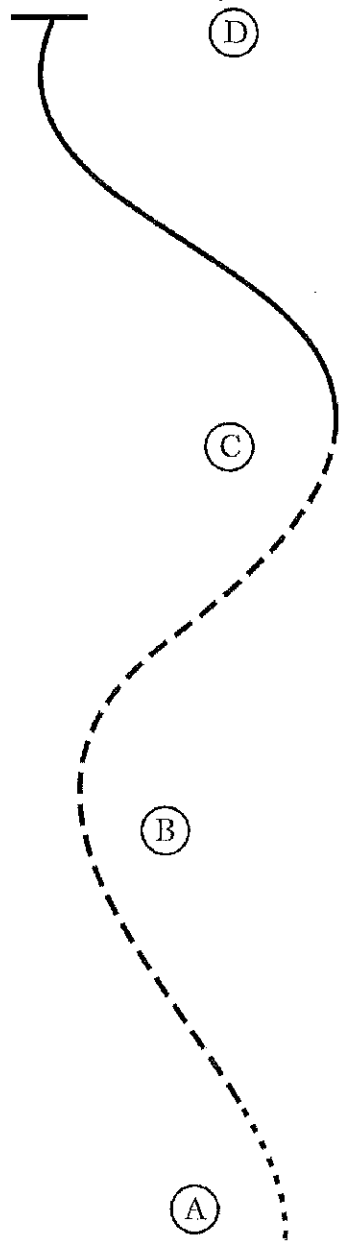

1. At A walk two strides
2. Jog to C
3. At C lope on the right lead to D
4. At D stop

Walk
Jog	-----
Extended Jog	—————
Lope	—————
Leg Yield	
Lead Change	↘
Back	← 3333 5555
Marker	(B)
Sidepass	←-----→

[WH/1-2]

3-2013

Pattern Provided by:

Montana 4-H State Horse Committee

Greenhorse - Level 2

used
2012

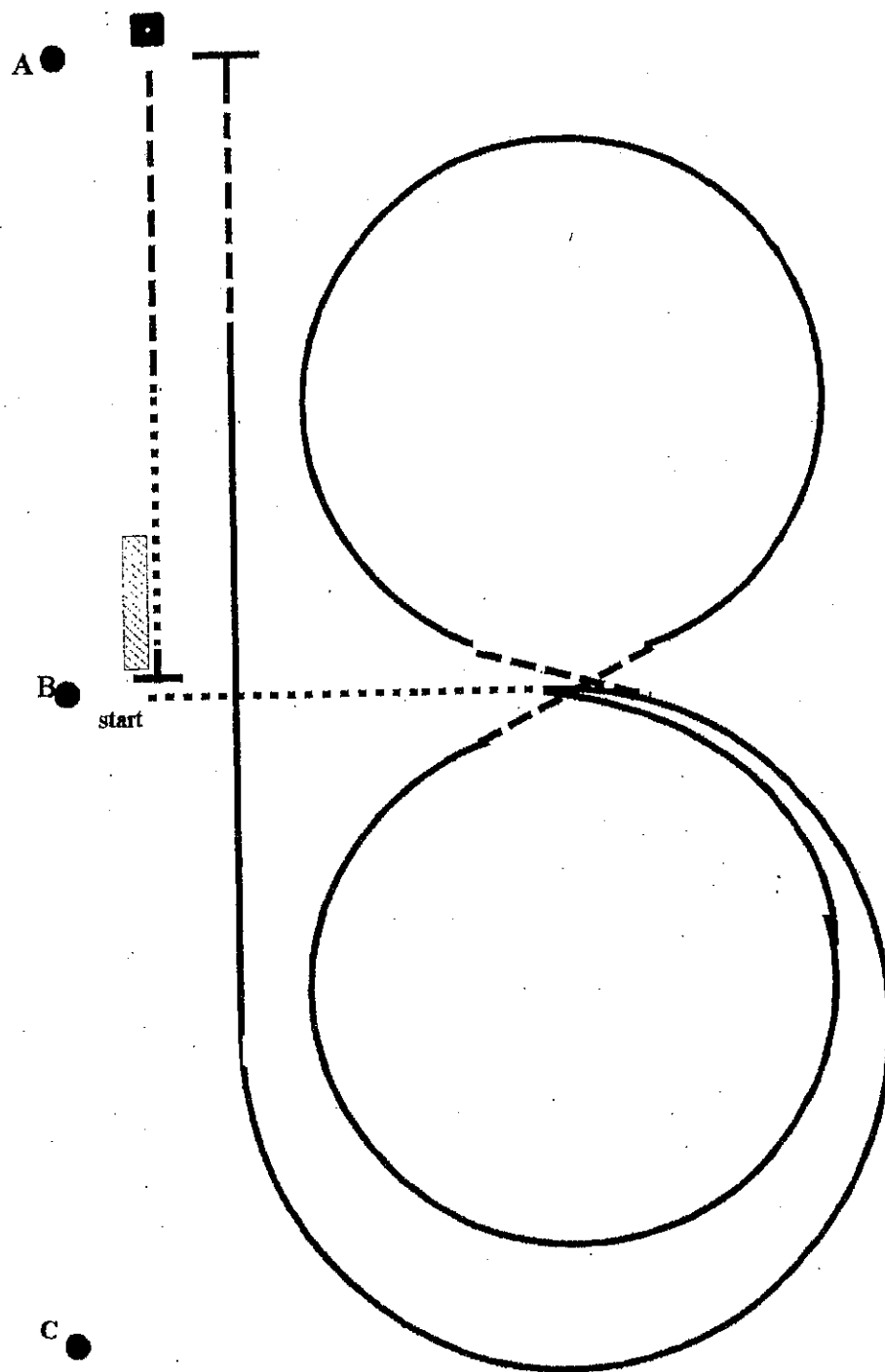

1. Walk to center. Pick up right lead and lope a circle.
2. Complete a simple lead change at center.
3. Lope a circle to the left with another simple lead change in the center.
4. Start right circle (don't close circle) but lope past center towards marker A. Break to jog.
5. Stop at marker A. Settle. Do a 180° hind quarter pivot to the left. Jog then slow to a walk and stop at marker B.
Back 10 steps.

Green horse Level 3

4569
2012

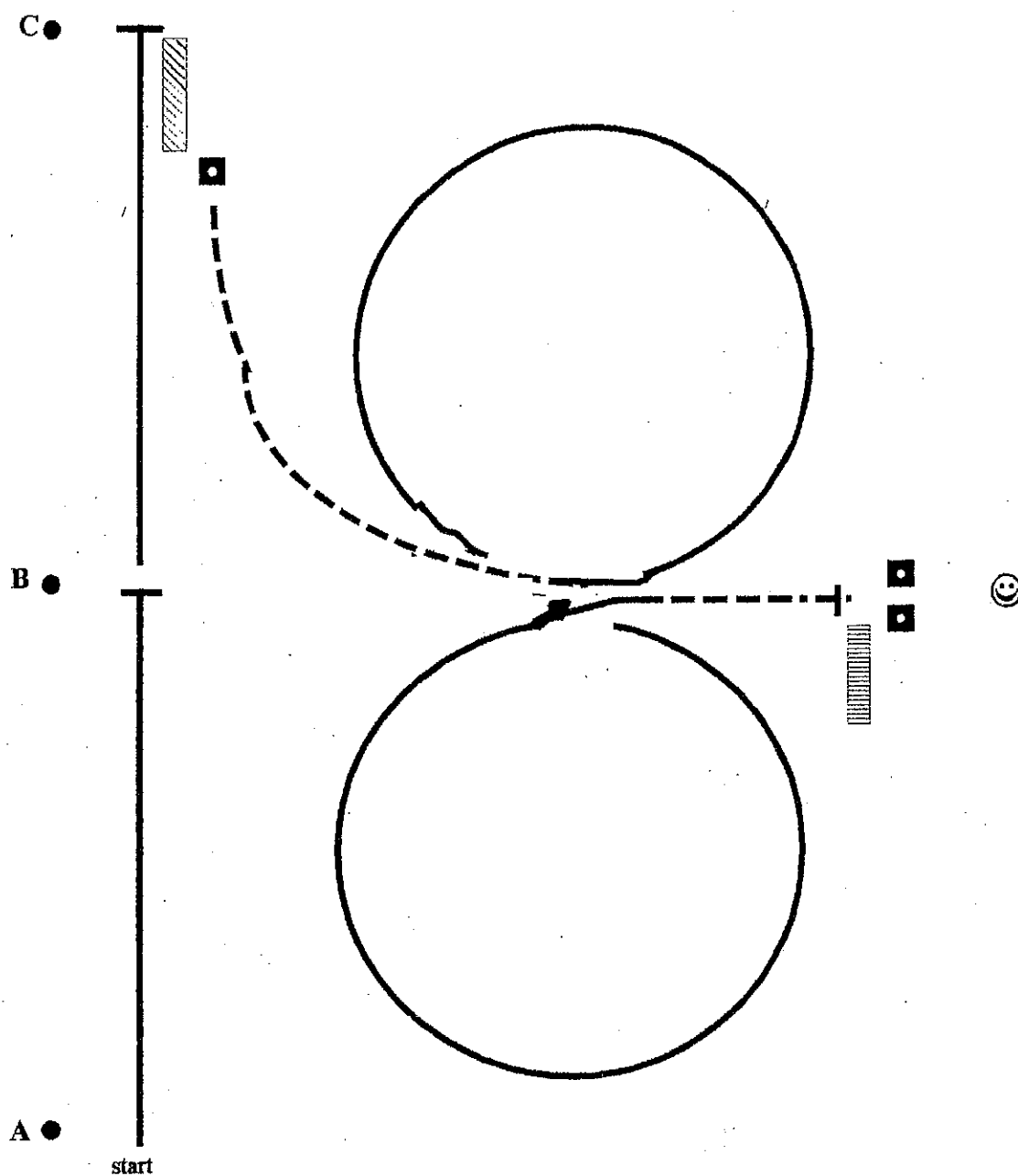

1. At marker A start lope in left lead. At marker B stop. Settle.
2. At marker B pick up right lead and lope to marker C. Stop. Settle. Back 10 steps. Do a 180° hindquarter pivot to the right.
3. Jog towards marker B picking up left lead to start figure 8. Execute a flying lead change at center.
4. After completing figure 8 break to jog. Jog towards judge. Stop. Settle. Sidepass right and left at least 6 ft. each way. Do a 360° hindquarter turn each way.

Ranch Horse Level 1

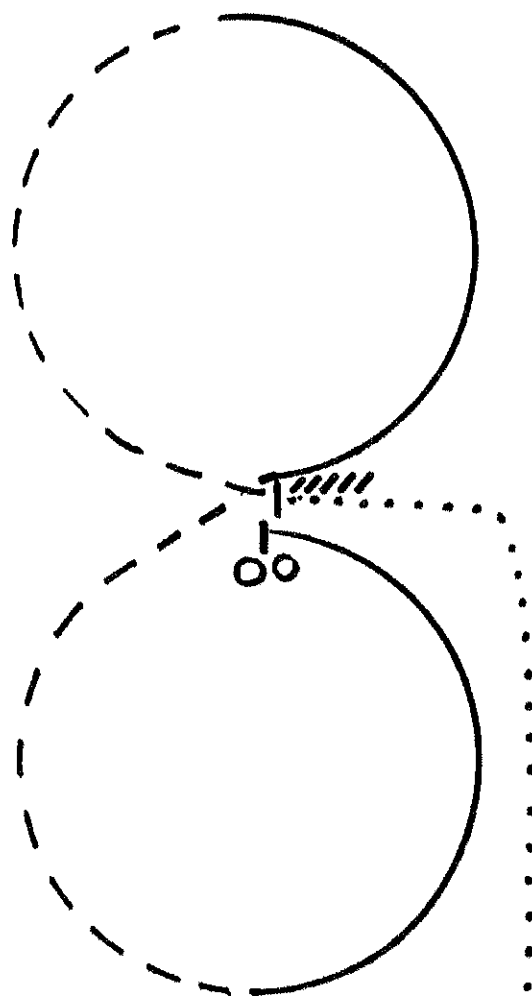

1. Walk to center
2. Stop in center facing judge
3. Back
4. Jog $\frac{1}{2}$ a circle to the right
5. Lope right lead to finish circle
6. Break to jog at center and jog $\frac{1}{2}$ circle to left
7. Lope left lead to finish circle
8. Stop
9. Perform 180° turn each way – either direction first

Ranch Horse Level 2

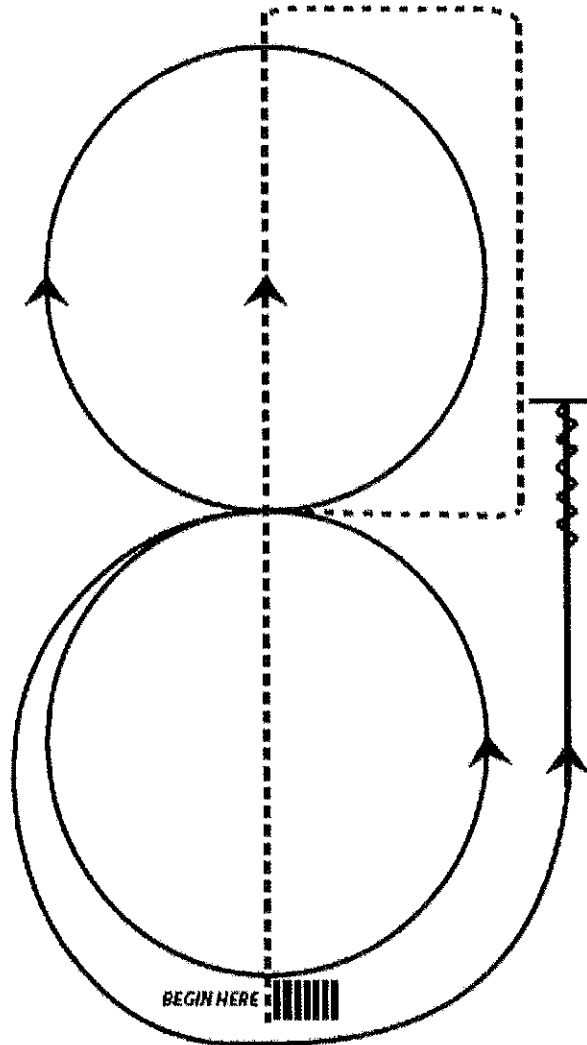

1. Side pass to the right 10ft; Side pass to the left 10 ft
2. Trot up center of arena, continue around the right perimeter of the arena
3. At center pick up right lead and lope 1 large circle to the right
4. At center do simple lead change to right liead
5. Lope 1 $\frac{3}{4}$ circles to left
6. Continue loping along fence past center; just beyond center stop
7. Back 10 ft

Ranch Horse Level 3

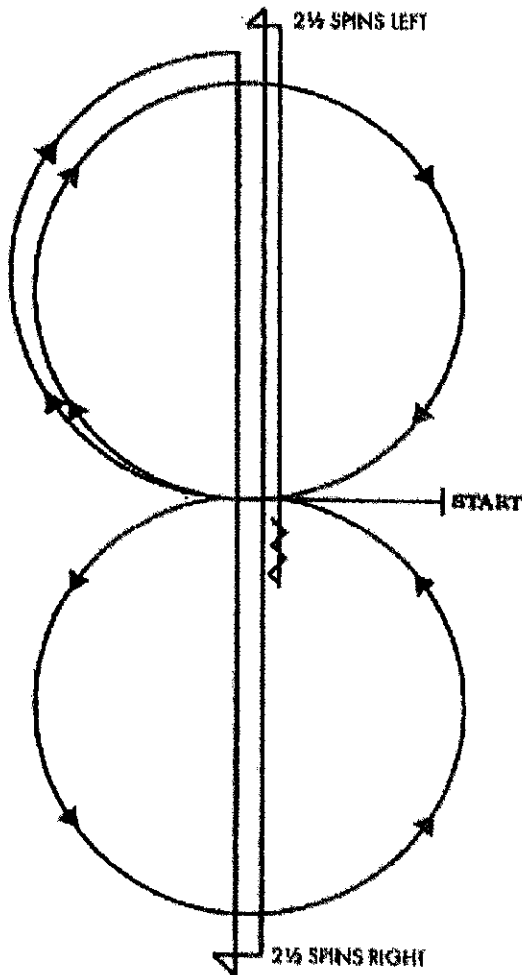

- Trot to center of arena and stop facing judge
1. Beginning on the right lead – lope once circle to the right.
 2. At center – change leads to the left (simple or flying) – lope one circle to the left.
 3. At center - change leads to the right – lope around top of circle and continue down center of arena.
 4. Run down past end marker and stop.
 5. Complete 2 ½ spins to the right.
 6. Run to other end of arena and past end marker come to a stop.
 7. Complete 2 ½ spins to the left.
 8. Run past center marker. Stop and back at least 10 feet.
 9. Pause to signify completion of pattern – then call for cow. (60 sec time limit for cow work)
 10. Box cow on end of arena
 11. Drive cow down fence past center and turn back (1 fence turn)

Ranch Horse Level 4

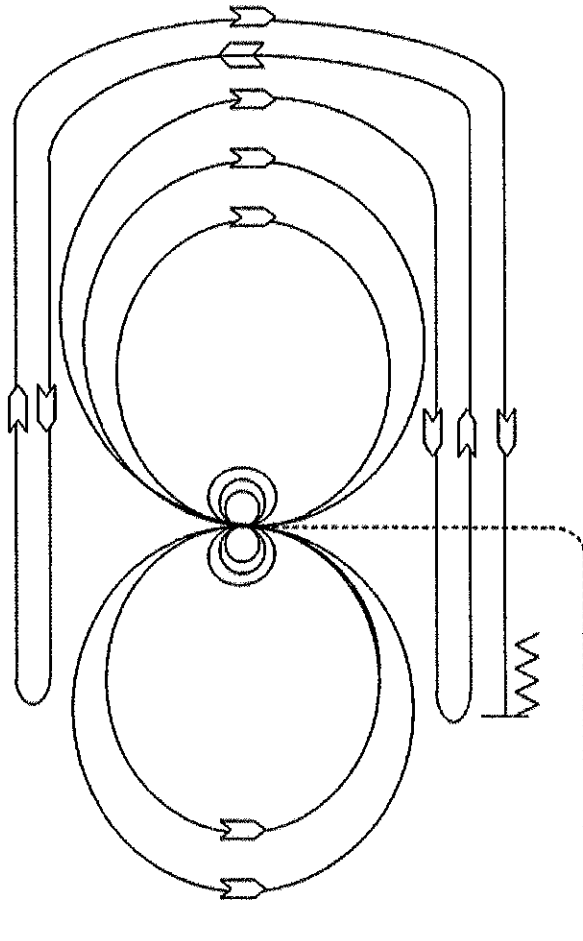

1. Trot to center of arena and stop.
2. Complete 2 spins in each direction.
3. Begin on right lead and lope large fast circle to the right followed by small, slow circle.
4. Change leads.
5. Lope on left lead a large fast circle followed by a small, slow circle.
6. Begin a large circle to the right but do not close. Run down right side of arena past center marker and do a left rollback.
7. Continue back around end of arena. Run down left side of arena past center marker and do a right rollback.
8. Continue back around end of arena. Run down past center marker and stop. Back up at least 10 feet.
9. Hesitate to show completion of pattern - then call for cow. (2 minute time limit for cow work)
10. Box cow on end of arena
11. Drive cow down fence and show 1 fence turn to each direction (turn must be past center marker)
12. Rope cow with breakaway honda -dally and stop OR circle cow in 1 direction

Pattern 4D

Marias Fair

MINIATURE SHOWMANSHIP - AGE 13 & UNDER

Show Date: July

W W W . H O R S E S H O W P A T T E R N S . C O M

W W W . H O R S E S H O W P A T T E R N S . C O M

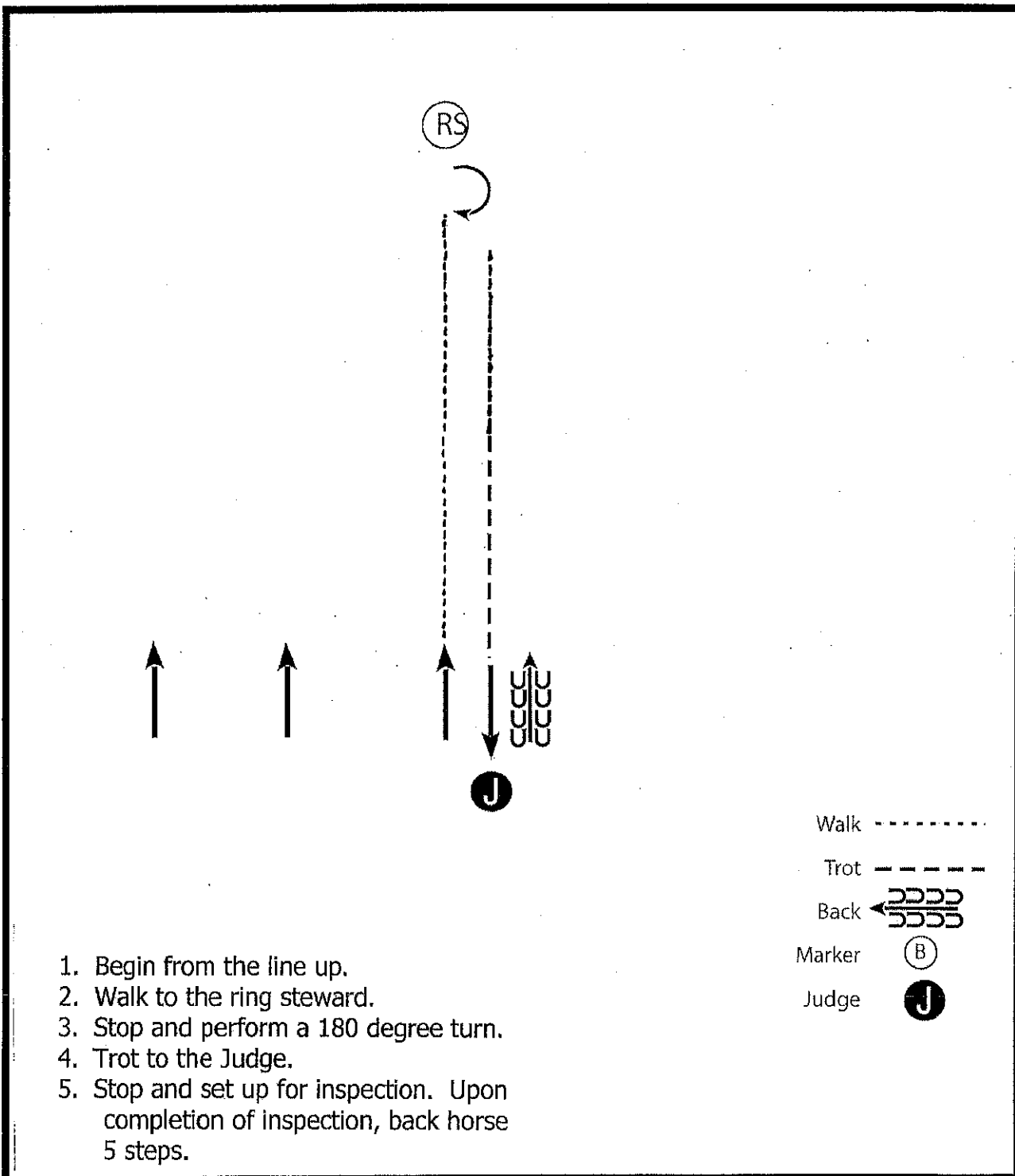

1. Begin from the line up.
2. Walk to the ring steward.
3. Stop and perform a 180 degree turn.
4. Trot to the Judge.
5. Stop and set up for inspection. Upon completion of inspection, back horse 5 steps.

Walk
Trot - - - - -
Back ←—————
Marker (B)
Judge (J)

[S/2-16]

Pattern Provided by:
Horse Committee

Marias Fair

MINIATURE OBSTACLE

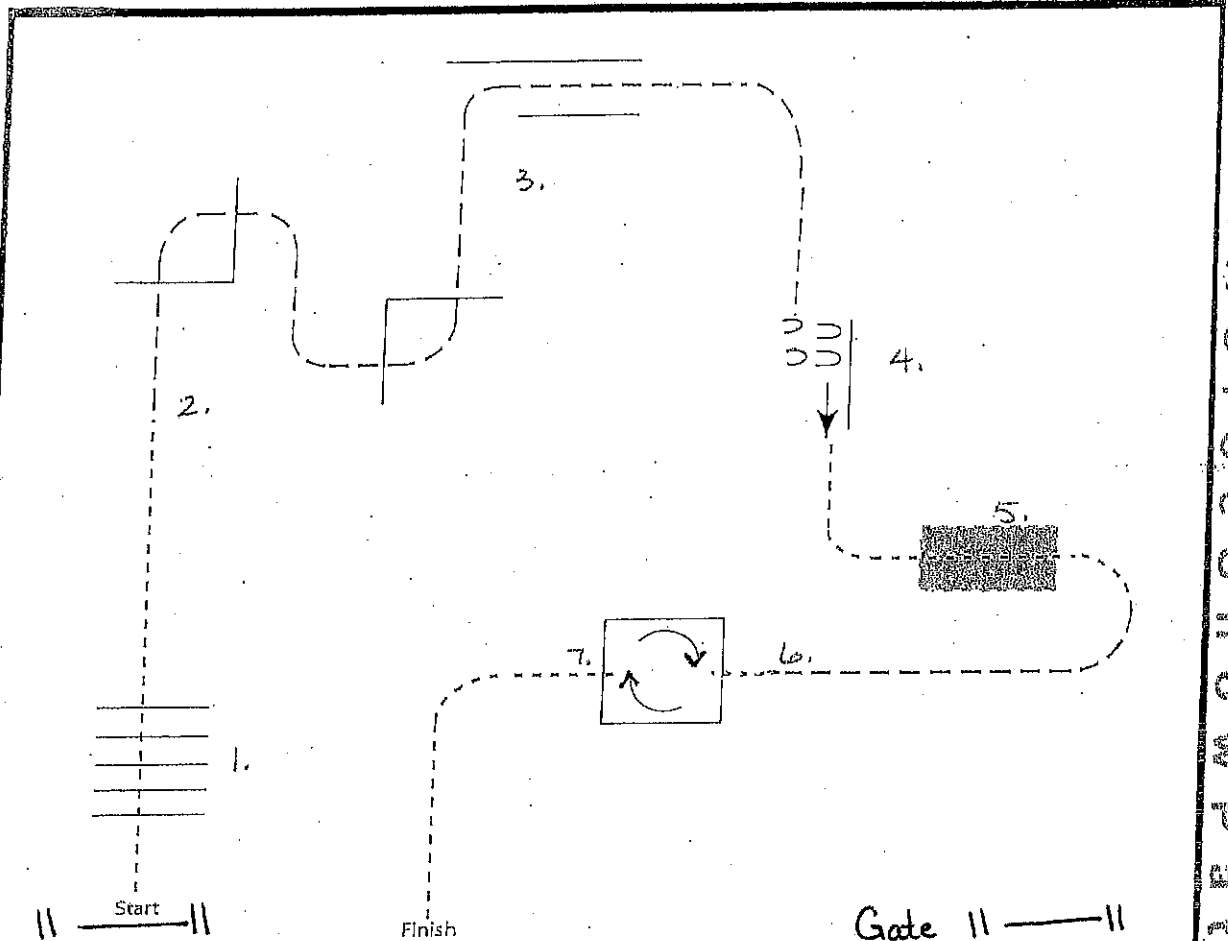

Open and close gate.

1. Walk over poles
2. Jog over poles
3. Jog through chute
4. Sidepass behind log to the right
5. Walk over bridge. Trot to box.
6. Walk into box and perform a 360° turn to the right.
7. Walk out of box to finish

Gate	———
Walk	-----
Jog	- - - - -
Extended Jog	- - - - -
Lope	—————
Leg Yield	
Lead Change	———/———
Back	←←←←←
Marker	(B)
Sidepass	←-----←

MARIAS FAIR HORSE SHOW PATTERNS

MARIAS FAIR HORSE SHOW PATTERNS

Pattern Provided by:
Horse Committee

[T/WT-5] X

Revised 3-2011